

# THE 21<sup>ST</sup> CENTURY HOUSE



# Successful Places

## *A Guide to Sustainable Housing Layout and Design for.*

- Bassetlaw District Council
- Bolsover District Council
- Chesterfield Borough Council
- North East Derbyshire District Council

## Supplementary Planning Document

2013

First Edition (Version 1.0)



## ACCESS FOR ALL

If you need help understanding this document or require a larger print, Braille, audio tape or translation, please contact us your local authority using one of the following methods:



### **Bassetlaw District Council**

**Department:**  
Planning and Building

**Tel:**  
01909 533533

**Text Message:**  
07797 800573

**Fax:**  
01909 501758

**Website:**  
[www.bassetlaw.gov.uk](http://www.bassetlaw.gov.uk)



### **Bolsover District Council**

**Department:**  
Planning Department

**Tel:**  
01246 242424

**Minicom:**  
01246 242450

**Fax:**  
01246 242423

**Website:**  
[www.bolsover.gov.uk](http://www.bolsover.gov.uk)



## **Chesterfield Borough Council**

**Department:**  
Planning Services

**Tel:**  
01246 345345

**Text Message:**  
07960 910264

**Fax:**  
01246 345252

**Website:**  
[www.chesterfield.gov.uk](http://www.chesterfield.gov.uk)



## **North East Derbyshire District Council**

**Department:**  
Environment & Planning

**Tel:**  
01246 217566

**Text Message:**  
07800 00 24 25

**Fax:**  
01246 217566

**Website:**  
[www.ne-derbyshire.gov.uk](http://www.ne-derbyshire.gov.uk)

## Adoption Dates

This document was adopted by each Local Planning Authority as follows:

Chesterfield Borough Council:

- 24th July 2013 (Supplementary Planning Document)

Bolsover District Council:

- 2nd October 2013 (Interim Supplementary Planning Document)

North East Derbyshire District Council:

- 1st December 2013 (Interim Planning Guidance)

Bassetlaw District Council:

- 3rd December 2013 (Supplementary Planning Document)

### Project Team:

#### Bassetlaw District Council

Tom Bannister, Principal Planning Officer

#### Bolsover District Council

Chris Doy, Development Control Manager

Philip Smith, Senior Urban Design Officer

#### Chesterfield Borough Council

Paul Staniforth, Group Leader Development Management

Scott Nicholas, Senior Planning Officer (Policy)

#### North East Derbyshire District Council

Adrian Kirkham, Head of Planning

Bryan Harrison, Economic Development Officer

#### Derbyshire County Council (Highways)

Graham Hill, Principal Engineer Development Control

Graham Fairs, Senior Project Engineer

#### Nottinghamshire County Council (Highways)

Martin Green, Principal Development Control Co-ordinator

### Acknowledgements:

**Cabe Enabler:** Graham Marshall, Maxim Urban Design

**Illustrations:** Richard Guise, Context 4D Urban Design

#### Permission to use images from:

Andrew Cameron, WSP

Borough Council of Wellingborough

Caunton Properties Ltd, Stirling Maynard and JWA Architects

Davidsons Group Ltd.

Groundwork Creswell, Ashfield and Mansfield

Homes and Communities Agency

Matrix Partnership Ltd Urban Design

Pinfold Securities and David Black Architects

Tibbalds Planning & Urban Design Ltd.

Walker Troup Architects

### OS Mapping:

All Ordnance Survey mapping reproduced in this document is under the Local Authority Licence (c) Crown Copyright and database right (2013). Ordnance Survey (100019526).

### Copyright:

The reuse of drawings or images utilised within this document is not permitted without the written permission of the relevant copyright holders as follows:

- Bassetlaw District Council;
- Bolsover District Council;
- Chesterfield Borough Council;
- North East Derbyshire District Council;
- Context 4D.

Use of material provided by third parties is not permitted without the permission of the original copyright holder.

## Foreword:

The design of residential developments and the quality of the places we create for ourselves is a reflection of societies values and the importance we attach to improving our quality of life. It is also our legacy, whether good or bad, for future generations, who must inherit what we design and build today.

In an era where concerns are often expressed about identikit towns where one place looks much like another, celebrating the differences between places becomes increasingly important to their identity and distinctiveness. However, standardisation, the rigid interpretation of highway regulations and a lack of appreciation for the places where developments are proposed often leads to further homogenisation of the built environment. All too frequently the quality of residential development falls below that which should be expected.

Designing sustainable places that minimise their impact on the environment is an additional dimension that all those involved in the development process have a responsibility to tackle and one which is increasingly seen as integral to the design process itself, rather than separate from it. The task of resolving often complex and competing issues associated with a development site is challenging, but one to which we must rise if we are to create the types of places we know can be achieved.

This guide provides the building blocks to creating better designed places to live, which are also relevant to where they are built. It also brings together the ideas of place making and sustainability into one document so that what we build today not only delivers character and distinctiveness, but the foundations for a better quality of life and well-being in the longer term.

We attach great importance to the quality of the places where we live. It is therefore essential that the homes and places we design today add to the character, richness and livability of our settlements and ensure that the legacy we hand on to the next generation is one we can all be proud of.

Councillor Jo White  
Portfolio Holder for Regeneration  
Bassetlaw District Council

Councillor Dennis Kelly  
Cabinet Member for the  
Environment  
Bolsover District Council

Councillor Terry Gilby  
Deputy Leader and Executive  
Member for Planning  
Chesterfield Borough Council

Councillor Harold Laws  
Portfolio responsibility for Planning  
and Licensing  
North East Derbyshire District Council

# CONTENTS:

How to use this Guide.....08

---

## 01 Introduction:

Challenge and Purpose.....11

---

- 1.1 Challenge and Purpose.....12
- 1.2 Coverage and Status.....13
- 1.3 Applying the Guide.....14
- 1.4 Policy Context.....15
- 1.5 Objectives.....17

## 02 Delivering Quality:

The Design Process.....19

---

- 2.1 Good Design.....20
- 2.2 The 21st Century House.....21
- 2.3 The Design Process.....22
- 2.4 Understanding the Place.....23
- 2.5 Context Appraisal.....26
- 2.6 Site Appraisal.....28
- 2.7 Design Principles and Concept.....29
- 2.8 Preparing Your Application.....30
- 2.9 Benchmarks and Review Processes...31

## 03 Place Making Principles:

Good Urban Design Practice.....35

---

- 3.1 Places for People.....37
- 3.2 Movement.....38
- 3.3 Green and Blue Infrastructure...42
- 3.4 Townscape.....44
- 3.5 Character.....46
- 3.6 Layout.....50
- 3.7 Block Structure.....56
- 3.8 Parking.....60
- 3.9 Street Design.....68
- 3.10 Public Realm Design.....70
- 3.11 Amenity.....74
- 3.12 Place Hierarchy.....82
- 3.13 Design for Corners.....86
- 3.14 Frontages.....88
- 3.15 Enclosure.....92
- 3.16 Building Design.....96
- 3.17 Adaptability.....102
- 3.18 Materials.....106
- 3.19 Servicing.....108

## 04 Management and Maintenance:

Enduring quality.....117

---

4.1 Adoption and Management.....118

4.2 Street Trees and Planting.....120

4.3 Managing Physical Assets.....121

Appendix.....123

---

Local Planning Policy.....124

National Planning Policy.....126

National Design Guidance.....126

### List of Tables:

---

Table 1: Minimum garage dimensions.....65

Table 2: Minimum garage set-back from edge of the highway.....65

Table 3: Minimum separation distances between neighbouring dwellings..75

Table 4: Minimum garden sizes/amenity spaces.....78

Table 5: Typical small retail/office dimensions.....104

Table 6: Bin storage requirements by Waste Collection Authority.....108

Table 7: Service vehicle dimensions by Waste Collection Authority.....112

## How to use this guide

This guidance supports the design policies in the Bassetlaw Core Strategy, the Chesterfield Borough Council Local Plan: Core Strategy and the saved Local Plans of Bolsover and North East Derbyshire District Council's.

It provides assistance to those involved in designing proposals for residential development, decision makers and other interested parties, by:

- Setting out the expected approach to the design process;
- Identifying and explaining the key design principles that should shape a design; and
- Identifying relevant considerations in respect of management and maintenance.

Please note that development proposals must also comply with all relevant Core Strategy or saved Local Plan policies and any other relevant Local Development Framework documents.

The following steps explain how the guide should be used.

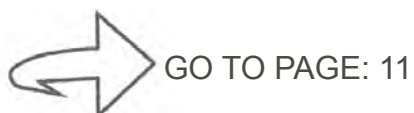

### 01 Introduction: Challenge and Purpose

Part 01 outlines the challenges to achieving good residential design in our area. It also:

- Identifies the local authority areas that are covered by this guidance.
- Identifies who should use the guide and the type of development it should be applied to.
- Summarizes the key local design policies and supporting guidance.
- Sets out the objectives for achieving more sustainable and better designed places.

#### Step 1

Start by familiarising yourself with the background, relevant policies and the objectives of the guidance. These provide the design context for the development.



### 02 Delivering Design Quality: The Design Process

Part 02 explains the expected approach to the design process to ensure that all proposals for residential development are informed by and responsive to their context. Key stages are:

- Step 1: Understanding the Place
- Step 2: Developing Design Principles
- Step 3: Developing a Design Concept

This section also includes advice on preparing your application and outlines benchmarks that may be used to help in assessing applications.

#### Step 2

Follow the steps of the design process in order to gain an appreciation of the site, its wider context, any assets, constraints and opportunities that may be presented. These should be evaluated and used to inform the approach to the design of the scheme.

Your appraisal work should be communicated in your design and access statement and explain how this has influenced the evolution of your scheme.







### 03 Place Making Principles: Good Urban Design Practice

Part 03 sets out good practice urban design principles. These are identified as:  
Many principles will apply to most housing proposals, whether urban or rural, but the relative importance of each is likely to vary according to the individual circumstances of the site. The principles are:

- 3.1 Places for People
- 3.2 Movement
- 3.3 Green and Blue Infrastructure
- 3.4 Townscape
- 3.5 Character
- 3.6 Layout
- 3.7 Block Structure
- 3.8 Parking
- 3.9 Street Design
- 3.10 Public Realm Design
- 3.11 Amenity
- 3.12 Place Hierarchy
- 3.13 Design for Corners
- 3.14 Frontages
- 3.15 Enclosure
- 3.16 Building Design
- 3.17 Adaptability
- 3.18 Materials
- 3.19 Servicing

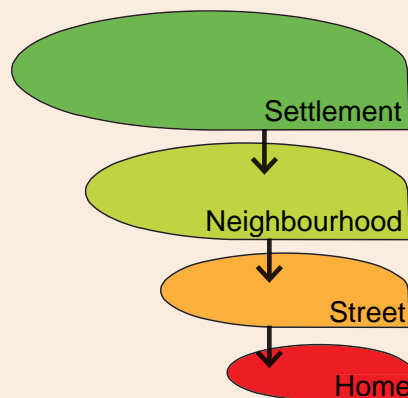

Some principles, such as *Movement*, will apply to all scales. Others, such as *Frontages* or *Servicing* arrangements are more localised at the street and home scale. Where a principle is unlikely to apply at a particular scale, only the relevant scales are illuminated (see below).

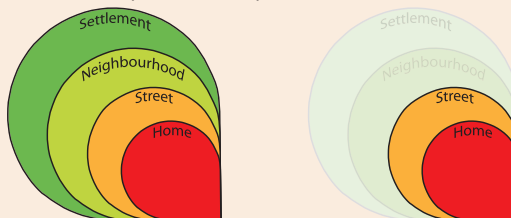

Part 03 also introduces the notion of *scale*. This is the idea that place making principles will relate to differing levels within a place or a development. Each principle is accompanied by an indication of the scales at which it is most likely to be applicable.

### 04 Management and Maintenance: Enduring Quality

Part 04 highlights a number of matters that relate to design and which will need to be considered to ensure the long term management and maintenance of the development. These include:

- Adoption of highways
- Safety and quality audits
- Swept path analysis
- Commuted payments
- Street trees and planting
- Managing physical assets

#### Step 4

Consider how you intend the place to be managed and maintained following completion of the development.

Are the highways or public spaces intended to be adopted? Will commuted payments be necessary? Other agreements may need to be entered into.

These choices may affect the approach to aspects of the design which need to be considered as the scheme develops

#### Step 3

Develop your concept into a more detailed scheme. Use the design principles to inform and shape the proposals in line with good practice. You will need to demonstrate how a proposal has had regard to, and responded to, these principles in the design of your scheme.



---

# Introduction:

## Challenge and Purpose

---

*“We cannot afford not to invest in good design. Good design is not just about the aesthetic improvement of environment, it is as much about improved quality of life, equality of opportunity and economic growth.”*

The value of good design, Cobe

- 1.1 Challenge and Purpose
  - 1.2 Coverage and Status
  - 1.3 Applying the Guidance
  - 1.4 Policy Context
  - 1.5 Objectives
-



## 1.1 Challenge and Purpose

### 1.1.1 The Challenge

This Supplementary Planning Document (SPD) responds to a recognised weakness in the design quality of residential developments within the sub-region. A housing audit of the East Midlands undertaken by the Commission for Architecture and the Built Environment (CABE, 2006) revealed that the East Midlands Region was the worst performing in England for housing quality. Lack of character, poor quality layout and public realm were consistent themes.

**1.1.2** Moreover, research in *The Northern Way: Residential Futures (Vol.1 2009)*<sup>1</sup> identified an important link between the residential offer of a place and its economic competitiveness. It noted that the quality of housing influences the ability of a place to attract and retain businesses and employees, playing an important role supporting the local economy.

**1.1.3** However, it is not just the calibre of housing that matters. The quality of places and the quality of life that they offer is just as important. This includes access to parks and green spaces, high environmental quality, a safe public realm, schools and a vibrant cultural offer. It comes down to whether somewhere is an attractive place to live. Quality of place therefore plays a central role in supporting local economic competitiveness.

### 1.1.4 The costs of poor design

Developments that have a negative impact on communities have an adverse long-term impact on society. They generate on-going costs in terms of increased maintenance burdens, policing, health care etc. that inflict social and financial costs on communities.

### 1.1.5 Sustainability

The built environment also has a major impact on the wider environment and green house gas emissions from buildings contribute to climate change. It is therefore imperative that our new homes are more sustainable than those that have gone before. The National Planning Policy Framework (NPPF) recognises that to achieve sustainable development, economic, social and environmental gains should be sought jointly and simultaneously through the planning system (paras. 7-9).

**1.1.6** This SPD provides the basis for a dialogue between the development industry and local authorities to promote the development of *successful places* and avoid creating further costly and unsustainable forms of development.

### 1.1.7 The Purpose of the SPD

The purpose of this SPD is therefore to respond to these challenges and provide guidance on the interrelated issues of design quality and sustainability. Ultimately, it is about providing places that enhance our quality of life.

**1.1.8** It also places emphasis on the design process itself and aims to ensure that designers think beyond the site boundary. This will ensure that proposals are based upon a good understanding of the place where it is to be built and create locally distinctive places that strengthen the character and role of our settlements.

**1.1.9** The NPPF places great importance on good design and the quality of places, recognising design quality as a *Core Planning Principle*, stating that planning should:

*“always seek high quality design and a good standard of amenity for all existing and future occupants of land and buildings” (para. 17);*

**1.1.10** Section 7 of the NPPF is dedicated to *Requiring Good Design*. It states that:

*“Good design is a key aspect of sustainable development, is indivisible from good planning and should contribute positively to making places better for people”. (para. 56).*

**1.1.11** Good design should therefore be seen as the norm, rather than the exception. By clearly setting out the processes and principles that are expected to be addressed by proposals, the SPD will provide a benchmark for design quality against which schemes will be assessed. If followed, the guidance will result in consistently higher quality and more sustainable places.

“Good design is inseparable from good quality of life. It is efficient, affordable, sustainable, inclusive and beautiful. It lifts the heart and inspires the mind. We need it now more than ever.”

Good design in a changing world (2010), Cabé

#### Reference



<sup>1</sup> The **Northern Way** initiative brought together partners across the North of England to work together to improve the economic competitiveness of the North and rebalance the UK. It undertook a range of research projects to further this objective and closed in 2010.



## 1.2 Coverage and Status

### Reference



<sup>2</sup>The Housing Market Area (HMA) is a geographical area which is relatively self-contained in terms of housing demand; the four authorities share similar issues with their housing markets, being influenced by their relationship to the major urban areas of Sheffield and Rotherham. The HMA authorities work collaboratively to address common challenges, sharing joint housing needs studies, a housing strategy and working together to attract external funding.

### Reference



<sup>3</sup>The Sheffield City Region comprises a collaboration of local authorities from South Yorkshire and the northern part of the East Midlands. It is one of eight Northern city regions which aim to bridge the productivity gap between the North and the average for England.

### Reference



<sup>4</sup>The Peak District National Park has its own distinct policies and Design Guide SPD (2007) that will apply to proposals for development inside the National Park boundary.

[www.peakdistrict.gov.uk](http://www.peakdistrict.gov.uk)

### 1.2.1 Coverage

The Councils of Bassetlaw, Bolsover, Chesterfield and North East Derbyshire have worked in partnership to prepare this SPD. Collectively these authorities form a contiguous geographical area. This is also identified as a distinct Housing Market Area<sup>2</sup> located within the Sheffield City Region<sup>3</sup>.

**1.2.2** Derbyshire and Nottinghamshire County Council Highway Authorities have also assisted in its preparation to ensure it is compatible with their requirements.

**1.2.3** The guidance applies to all four adjoining local planning authorities and will therefore provide consistency and certainty to developers working in these areas.

**1.2.4** The Peak District National Park<sup>4</sup> (PDNP) is the planning authority for development within the PDNP, which includes part of the North East Derbyshire District Council area. This guidance does not apply to proposals inside the PDNP.

### 1.2.5 Status of the Guide

This document supports the adopted Core Strategy policies of Bassetlaw District Council and Chesterfield Borough Council and the saved Local Plans of Bolsover District Council and North East Derbyshire District Council. It is a material consideration in the determination of planning applications for new housing development. Where this document has *Interim* status it will be reviewed and adopted as a full SPD following adoption of the relevant new Local Plans. It currently has the following status within each authority:

**Supplementary Planning Document (SPD)**  
Bassetlaw District Council  
Chesterfield Borough Council

**Interim SPD** - Bolsover District Council

**Interim Planning Guidance** - North East Derbyshire District Council

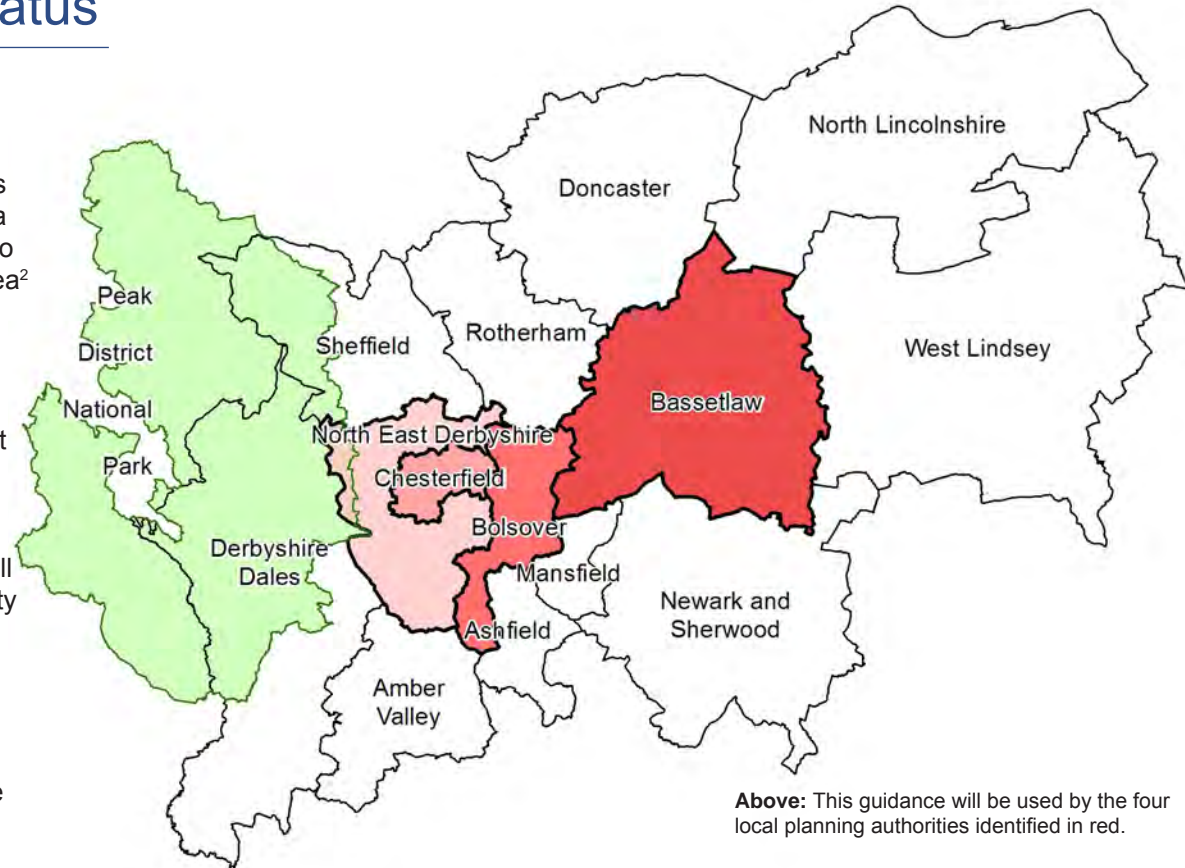

Above: This guidance will be used by the four local planning authorities identified in red.

## 1.3 Applying the Guide

### 1.3.1 Who is the guide for?

The Councils have prepared this guide as a tool to support developers, their design professionals and agents in preparing proposals for residential development or mixed use comprising both commercial uses and housing.

**1.3.2** It is also intended for use by local authority officers, councillors and communities to facilitate and inform the design discussions and assist them in the delivery of high quality, sustainable places to live.



The SPD should provide the platform for dialogue between developers and local planning authorities, supporting both applicants and decision makers in delivering successful places.

### 1.3.3 What type of development does this guidance apply to?

The guidance covers all forms of residential development including mixed use schemes that incorporate commercial activities and residential accommodation.

**1.3.4** Most residential development will take place within or on the edge of an existing settlement and this will form the context within which it must be considered.

**1.3.5** The range of development scenarios likely within the area covered by this SPD are:

**Urban Centres** – proposals within or adjacent to existing town/district or village centres with potential for intensification or redevelopment of existing sites.

**Infill** – proposals for infilling gaps or redeveloping existing sites within existing urban or rural settlements.

**The Edge** – proposals for town or village expansions, whether large or small.

**1.3.6** Part 02 of this guidance sets out the design process which is expected to be followed in order to demonstrate that the development proposal is based upon a clear appreciation of the site and its wider context.

**1.3.7** It also identifies a number of benchmarks that will be used to assist in the assessment of residential proposals, including design review and Building for Life12 (BfL12) criteria associated with each place making principle (see 2.9).

**1.3.8** Part 03 of this guidance sets out the place making principles that will be used for assessing proposals for residential development. Depending on the design issues the principles will apply at a range of scales. Some principles will only be relevant to larger scale schemes, while others are appropriate at all scales of development, including proposals of less than 10 dwellings. Whatever the scale of the proposal many of the principles will be applicable whether urban or rural.

**1.3.9** Part 04 outlines issues in relation to management and maintenance to ensure that long term quality is achieved.

**NOTE:** The drawings in this guide have been prepared to support the design principles and illustrate how they can be implemented. They show generic built form and do not imply a standard stylistic preference.

*The built environment is one of our largest long term investments and amongst our most important assets. On that basis there is no excuse for poor design.*

Good Design: The Fundamentals, (2009), Cabe



## 1.4 Policy Context

### 1.4.1 Design Policy Context

The guide supplements the requirements of national and local planning policy with the aim of producing consistently high quality outcomes.

**1.4.2** Proposals that follow the guidance are more likely to move through the planning process quickly and successfully.

**1.4.3** The Planning Act 2008 (s.183) requires local authorities to have regard to the desirability of achieving good design. This SPD contributes to meeting the duty placed on local authorities by the Act.

**1.4.4** The National Planning Policy Framework (NPPF) recognises the importance and value of good design as an essential component of sustainable development. The relevant references to design in the NPPF are set out below (1.4.14). In addition national good practice design guidance is set out in the Appendix.

### 1.4.5 The SPD in the Local Policy Context

The Local Plans of each Partner Council are at varying stages of completion. These will set out the strategy and proposals for future development in each area. For Chesterfield Borough Council and Bassetlaw District Council the SPD will supplement their adopted Core Strategy design and other related policies. For Bolsover and North East Derbyshire District Council's the SPD will supplement the relevant policies from their saved local plans, until each has an up to date replacement Local Plan in place.

**1.4.6** In the future, the partners will revise and update the SPD when each has an adopted local plan in place.

**1.4.7** The following provides an overview of the key policies as they relate to residential design at the time of writing. Other design related policies are set out in the Appendix.

### 1.4.8 Bassetlaw District Council

Bassetlaw has an up to date Core Strategy which was adopted in December 2011. Policy **DM4: Design & Character** is the key policy regarding residential development.

### 1.4.9 Bolsover District Council

The Bolsover District Local Plan (2000) contains a number of general design and housing policies that provide the criteria for assessing new residential development, including the requirements for open

space, parking and road design. The key policy is **GEN 2: Impact of Development on the Environment** that aims to ensure that residential development respects the immediate locality by utilising appropriate materials and considering landscape and setting.

### 1.4.10 Chesterfield Borough Council

The council's policies are contained within the adopted Local Plan: Core Strategy (2011-2031). The key policy is **CS18: Design** which recognises that good design is fundamental to sustainable development and that raising the quality of the environment is one of the Core Strategies main challenges.

**1.4.11** The council has also adopted a other Supplementary Planning Documents (SPDs) that provide more detailed guidance to assist proposals for new development. The most applicable of these SPDs to housing proposals is:

- **Designing Out Crime SPD (2007)** - discourages anti-social behaviour and crime in new development by careful attention to design.

*The Government attaches great importance to the design of the built environment. Good design is a key aspect of sustainable development, is indivisible from good planning, and should contribute positively to making places better for people.*

Para 56. National Planning Policy Framework (2012), DCLG

**Useful References**

*By Design: Urban Design in the Planning System: towards better practice* (2000) Cabe/DETR

*Urban Design Compendium 1 & 2* (2007), English Partnerships

*Better Places to Live by Design: A Companion Guide to PPG3* (2001), Cabe/DETR

*Building for Life 12: The sign of a good place to live* (2012), Cabe at the Design Council, Home Builders Federation, Design for Homes

*Manual for Streets* (2007), DoT

*Manual for Streets 2* (2010), Institute of Civil Engineers

*Safer Places: The Planning System and Crime Prevention* (2004), ODP/Office

Code for Sustainable Homes Technical Guide, November 2010, CLG (N/B the technical guide is updated at intervals if standards change or new technologies or processes change)

Housing Audit: Assessing the design quality of housing in the east Midlands, West Midlands and the South West (2007), Cabe

### 1.4.12 North East Derbyshire District Council

The North East Derbyshire Local Plan (2001 – 2011) contains a number of policies relating to the built and natural environment which are relevant to new housing proposals. Policy H12: *Design and Layout of New Housing* is the key policy. This stipulates standards for details of design, materials, scale, form and access. Policy BE1: *General Design Principles* also requires that proposals recognise the character of the surrounding area and create safe places to live.

1.4.13 The council has also adopted a number of Supplementary Planning Documents (SPDs) which provide more detailed guidance in relation to new development, including housing. These are the following:

- **Access for All SPD** (2007) – highlights the most important principles in designing inclusive buildings and provides advice on the preparation of Design and Access Statements.
- **Affordable Housing SPD** (2008) – provides a clear framework for affordable housing provision and ensures an appropriate mix of sizes and types of affordable housing is integrated into the district's towns and villages to create sustainable communities.
- **Recreation and Open Space SPD** (2007) – provides guidance on the local recreation standard and explains the council's requirements for the provision of

open space and recreation facilities in new developments.

- **Developer Contributions SPD** (2007) – sets out the council's approach to securing developer contributions.

### 1.4.14 National Planning Policy Framework (NPPF)

The NPPF puts a presumption in favour of sustainable development at the heart of the planning system (para. 15) and states that good design is a key aspect of sustainable development which is indivisible from good planning (para. 56).

1.4.15 Twelve 'core planning principles' are at the heart of the NPPF. These include:

- **Always seek to secure high quality design and a good standard of amenity for all existing and future occupants of land and buildings.**
- **Support the transition to a low carbon future in a changing climate... encourage the reuse of existing resources, including the conversion of existing buildings and encourage the use of renewable resources (for example by the development of renewable energy).**
- **Promote mixed use developments, and encourage multiple benefits from the use of land in urban and rural areas, recognising that some open land can perform many functions (such as for wildlife, recreation, flood risk mitigation, carbon storage, or food**

production - para. 17).

1.4.16 The NPPF acknowledges that it is proper to seek to promote or reinforce local distinctiveness (para. 60) and that designs should address the connections between people and places and the integration of new development into the natural and built environment (para. 61).

1.4.17 Poorly designed development or that which fails to take the opportunities available for improving the character and quality of an area and the way it functions should be refused (para. 64).

1.4.18 The NPPF also emphasises the importance of the communities developing their own neighbourhood plans to provide a framework to influence the design issues and shape the character and quality of development for their areas. Where neighbourhood plans are proposed these must support sustainable growth including through the conversion of existing buildings and well designed new buildings (para. 28).





## 1.5 Objectives

**1.5.1** Fundamentally, the purpose of this guide is about creating sustainable places that deliver a good quality of life for the people that will live there and preventing costly poor design. This demands that our neighbourhoods are designed around the linked concepts of good place making and sustainability.

**1.5.2** The built environment is responsible for 43% of the UK's carbon dioxide emissions<sup>4</sup>. The design and layout of our settlements has a major influence on our patterns of behaviour, movement and transport choices. The design and construction of the buildings themselves, also has a direct impact on the environment, in terms of their energy efficiency, water consumption/management, health and well being etc. The right design choices at the outset can help create more sustainable successful places.

**1.5.3** The Government places great importance on the design quality of the built environment, recognising that the planning system should promote good design that ensures attractive, usable and durable places and this is a key element in achieving sustainable development<sup>5</sup>.

**1.5.4** The following objectives underpin this guidance and complement the policy objectives set out in the NPPF. They embrace the principle of sustainable development, not as a separate 'add on' but as integral to this guidance.

### 1. Design Quality:

To improve the quality of design and attractiveness of residential development.

### 2. Low Impact:

To promote design that is adapted to climate change and contributes to reducing the impacts of construction, maintenance and running of residential buildings on both the immediate and wider environment and on climate change.

### 3. Local Distinctiveness:

To ensure that the design of new residential development recognises and enhances the townscape, landscape character and local distinctiveness of the area including the setting of historic buildings and biodiversity.

### 4. Context:

To ensure that new residential development is designed on the basis of an understanding of its context and the site conditions so as to enhance the quality of existing settlements and townscapes.

### 5. Quality of Life:

To promote the design of residential development that provides a safe and secure environment and meets the practical and social needs of residents, creating places where people will want to live.

### 6. Accessibility:

To ensure that the design of residential development facilitates safe, sustainable and convenient access for all users, are well integrated with their surroundings with good access to local facilities and that layouts and buildings are legible and designed to be inclusive.

<sup>4</sup>2009 final UK greenhouse gas emissions (data tables), Department of Energy and Climate Change, UK Greenhouse Gas and Statistics Inventory

<sup>5</sup>National Planning Policy Framework (2012)



STRATTON ROAD

---

# DELIVERING QUALITY:

## The Design Process

---

*“Context is the character and setting of the area within which a projected scheme will sit... A thorough appreciation of the overall site context is the starting point for designing a distinctive place.”*

Urban Design Compendium 1 English Partnerships & The Housing Corporation

- |            |                         |            |                                 |
|------------|-------------------------|------------|---------------------------------|
| <b>2.1</b> | Good Design             | <b>2.6</b> | Site Appraisal                  |
| <b>2.2</b> | The 21st Century House  | <b>2.7</b> | Design Principles and Concept   |
| <b>2.3</b> | The Design Process      | <b>2.8</b> | Preparing Your Application      |
| <b>2.4</b> | Understanding the Place | <b>2.9</b> | Benchmarks and Review Processes |
| <b>2.5</b> | Context Appraisal       |            |                                 |
-

## 2.1 Good Design

**2.1.1** Everything that is made is the product of having been through a process of design and the built environment is no exception. However, good design does not just happen by itself, it is the result of a creative process and involves not only good designers but a commitment from key decision makers to achieving it.

**2.1.2** High quality places transcend subjective issues of personal taste, style or architectural fashion, with three fundamental principles at the core of design excellence:

**Firmness:** Is it built to last, easily maintained and able to be adapted over time? Essentially, is it durable?

**Functionality:** Is it useful, fit for purpose and easy to use? Will it contribute to a good quality of life? Essentially, does it work?

**Delight:** Is it visually pleasing or even beautiful? Does it engender a sense of pride? Essentially, does it look good?

**2.1.3** Ultimately, it is about creating buildings and places that are well built, will work well and that look good. Working on these principles of good design will help deliver successful places and balancing these objectives does not need to add expense to the project (Cabe, Evaluating Housing Proposals Step by Step, 2008). Achieving good design should be the aim of all those involved in delivering residential development.

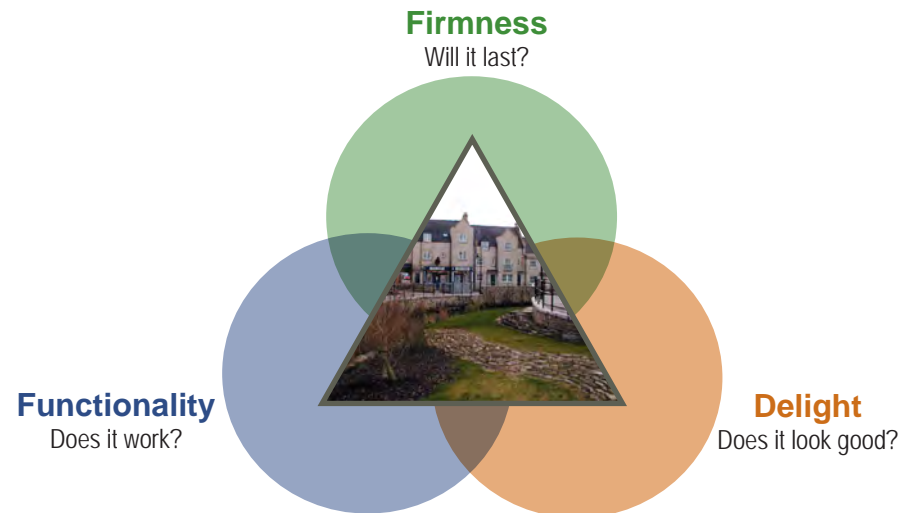

(Source: Cabe, Evaluating Housing Proposals Step by Step, 2008)

This set of principles is not new but it can be applied to help everyone recognise a well-designed building or place. This should give us all the confidence to identify and understand the kinds of places that work well and that we want to create.

Applying the three principles, we will know that buildings and public spaces are well designed if:

- They are useful, built to last and easy to care for.
- You can find your way and move around easily, regardless of whether or not you are disabled, in a place in which you feel safe.
- They relate well to the place where they are built; this might mean fitting in quietly or creating new context and new landmarks, depending on circumstances.
- They are flexible and their use can change over time (examples being period terraced housing and mill buildings from the early industrial revolution).
- They are environmentally efficient and will help us all to live and work sustainably.
- The people who use them tell you that they help them to work more effectively and deliver services more efficiently.
- The people who live there tell you that their quality of life has improved, and they continue to say this over time.
- People tell you that they are proud of where they live because their building or place has real identity, character and beauty.

(Source: Cabe, Good design: the fundamentals, 2009)



“...it is possible to design well in a variety of styles. The important thing is that 21st century society has the opportunity to contribute worthy additions to the accumulating pattern that makes up our towns and cities.”

Good design: the fundamentals, Cabe, 2009

## 2.2 The 21<sup>st</sup> Century House

**2.2.1** What should we expect from our neighbourhoods and homes in the 21<sup>st</sup> century? What types of places should we be creating for people to live in?

**2.2.2** The 21<sup>st</sup> century house is a concept that embodies what is reasonably expected from our new neighbourhoods and homes. They should be ‘fit for purpose’ in the way that they function, attractive and distinctive places that contribute positively to the character of the place and will stand the test of time.

**2.2.3** The diagram outlines the key attributes of the ‘21<sup>st</sup> century house’. These qualities are fundamental to the design and development of *successful places*. They represent reasonable expectations for any new housing development and are all aspects of guidance contained within the National Planning Policy Framework (2012).

**Delivering these expectations should be the aspiration of all those involved in the development process.**

### THE 21<sup>ST</sup> CENTURY HOUSE



“It is clear that we need to build more homes... But in the rush to do so, we need to think about what we are building.”

Its easy to think about housing numbers, percentages, bricks and mortar. But we should not forget that housing is fundamentally about people.”

The Case for Space, RIBA, 2011



## 2.3 The Design Process

**2.3.1** Part 02 of this SPD outlines a step by step approach to the design process that is founded on a clear appreciation of the site characteristics and its wider context. This should provide the basis for design-led decision-making and formulating the principles for the development of the site.

**2.3.2** The applicants design team should include suitably qualified people with the right skills and experience to deliver a successful place. The range of professions and skills required should be appropriate to the scale and complexity issues raised by the proposal.

**2.3.3** Where appropriate, different skills should be brought in to design particular aspects of a project e.g. urban designers for master planning, context appraisal and concept development, architects for building design and creative thinking, landscape architects for public realm design, engineers to advise on ground conditions, drainage and so on. Often the team will need to work collaboratively to create successful places.

**2.3.4** The design process diagram (pages 22 - 23) outlines the recommended approach. This should form the basis of a 'design agenda' and discussion with the local planning authority when preparing proposals for a site.

**Note:** The following pages outline the recommended approach to the design process. This is based upon first developing a sound understanding of the place and using this to inform the subsequent development of the design.

*The designers first duty must be to study the town, the site, the people and their requirements.*

Patrick Geddes, Pioneering town planner

### Useful Reference



Building in Context Toolkit  
[www.building-in-context/toolkit](http://www.building-in-context/toolkit)

Founded on the principle that all successful design solutions depend on a thorough site analysis and character appraisal of the context. Although intended as a tool for development proposals in historic settings the 8 key principles are equally applicable to any site.

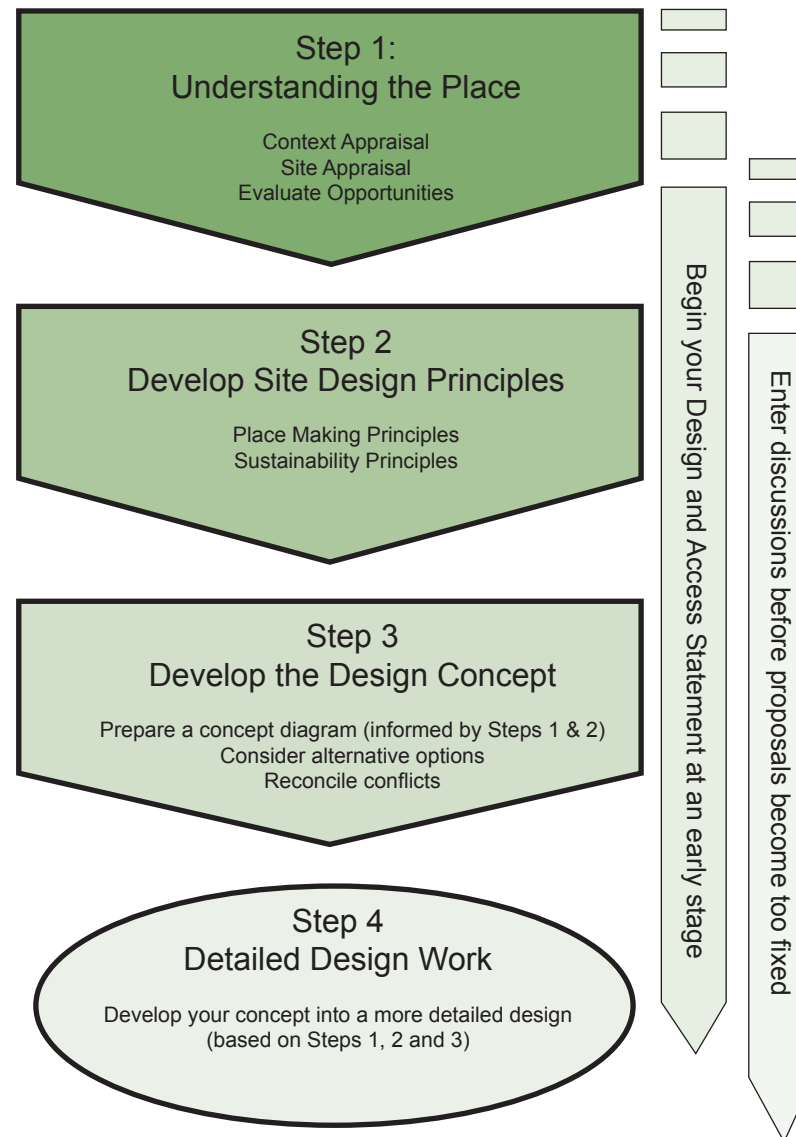



## 2.4 Understanding the Place (Step 1)

**2.4.1** This SPD sets out a framework to assist developers in demonstrating that they have followed a rational design process. In determining an application for planning permission, the Local Planning Authority will consider how the developer has incorporated the design objectives and the recommended design process into the evolution of the scheme.

**2.4.2** The NPPF (2012) states that it is proper to seek to promote or reinforce local distinctiveness (para. 60) and that permission should be refused for development of poor quality that fails to take the opportunities available for improving the character and quality of an area and the way it functions (para. 64). As such, it is essential developers/designers first look at and understand the place where they are proposing to build. Schemes designed without regard to context lack character, distinctiveness and could be 'anywhere places', devoid of identity or relevance to their location.

**2.4.3** Many development proposals only consider the site in isolation from the place where they will be built. Without a good understanding of the place, its character and how it functions; proposals are more likely to be inward looking and less likely to make a positive contribution to the character and distinctiveness of the area.

**2.4.4** Undertaking a context and site appraisal is the process of assessing the physical, environmental, economic and social characteristics of a place. This will involve considering the value and quality of the site, component elements and its surroundings, including areas of particular character, views, buildings, landscape or other features and how they contribute to the character of the place. These all require careful consideration in the design of any future development proposals.

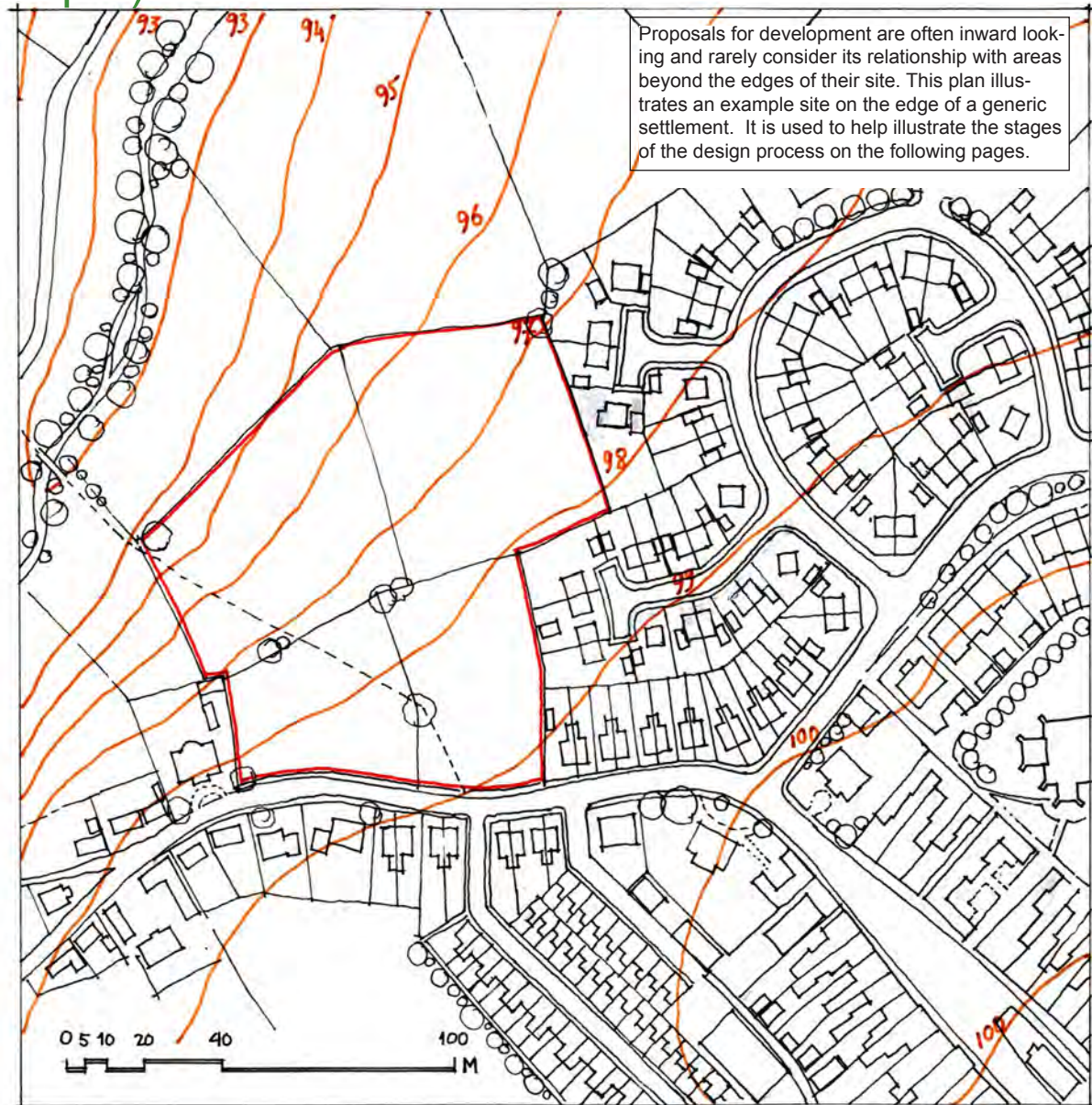

# The Design Process

## Step 1

### Initial Work...

**Site Location:** Is it an appropriate location for the proposed use and scale of development?

**Design Team:** Put together a team with the appropriate design skills and experience to deliver the scheme. A range of professional skills may be required depending on the proposal.

**Planning Policy:** What are the relevant planning policies and how might they influence development of the site?

**Constraints:** Are there any major constraints that need to be identified at an early stage?

**Community Needs:** How have local needs or aspirations been considered and taken into account? (neighbourhood plans, local housing need in terms of accommodation and tenure mix etc)

**Design and Access Statement:** Start preparing this now - each stage should be recorded and communicated in your design statement.

## UNDERSTANDING THE PLACE

### Context Appraisal

**Wider Setting:** How would the proposals relate to the wider area in terms of landscape, topography, views, scale, pattern and character of development? Are there constraints that will influence the scheme?

**Designations:** Do any designations affect the setting? (Green Belt, Conservation Area, ecological designations e.g. SSSI, etc)

**Access:** Potential connections/ approaches and access routes/points? (pedestrian, cycle and vehicular)

**Facilities:** What facilities are located nearby (shop/school/bus stop etc), how far are they/what are the likely routes?

**Public Transport:** Is public transport nearby? How far is it? Is it a good level of service or infrequent?

**Settlement Character:** What is the character of the built environment? (scale, pattern, grain, age, materials etc)

**Landscape Character:** What is the landscape character of the site and its surroundings? (views in/out, vegetation, edges etc)

### Site Appraisal

**Constraints:** Identify constraints that might affect design/layout? (heritage assets, utilities, ground instability etc)

**Amenity:** Are there sensitive edges that require a careful response in terms of amenity? (existing/future occupants etc)

**Designations:** What designations affect the site directly? (ecological or heritage designations, TPO's, etc)

**Access:** Are there existing/potential access points, RoW, desire lines or footpath links to surroundings?

**Geography:** How will the topography influence the scheme? (character, views, layout, drainage, energy etc)

**Built Features:** Determine the value of any existing structures, buildings or walls in terms of their contribution to character and local distinctiveness.

**Natural Features:** Determine the value of any natural features in terms of their potential contribution to site character and biodiversity (trees, hedges, water features, habitats, rock outcrops etc)

### Evaluate Site Opportunities

Developer Objectives & Funding vs Actual Site Constraints. CHECK with LPA at early stage

Area of Site Theoretically available for development

Area of Site Actually available due to....

setting of Listed Building

High Flood Risk

noise/air quality area character

BUSY ROAD

TPO



## Step 2

### DEVELOP SITE DESIGN PRINCIPLES

#### Place Making Principles

**Evaluation:** Evaluate the information and issues identified through the context and site appraisal process and formulate the place making principles that will shape the form, layout and character of the development.

How has the appraisal influenced the approach to the development and shaped its character? Such as:

- Constraints, such as flood zones.
- Incorporation of positive features such as valuable landscape/built features.
- Respect locally distinctive buildings/traditions.
- Townscape, scale, built character, important views, routes to facilities etc.

**Role:** What role will the development play in terms of place making? Such as gateway/entrance, focal point, landmark, important corner, skyline, settlement edge, creation of frontage etc. N/B it may have more than one role.

**Place Making Principles:** Should be shaped by the context/site specific considerations. **ENSURE:**

- Active frontages.
- Amenity (light, privacy, storage etc).
- Parking/roads do not dominate.
- Features, materials, elevations, details appropriate to context/aesthetic.

#### Sustainability Principles

**Evaluation:** Evaluate the information and issues identified through the context and site appraisal process and formulate the principles that will contribute to the schemes sustainability.

How has the appraisal influenced the development and shaped the approach to sustainability? Such as:

- Proximity to local facilities/transport.
- Positive natural features.
- Meeting local housing needs (types/tenure),
- Links to green infrastructure and routes.
- Opportunities for low/zero carbon energy.
- Incorporate green/blue infrastructure/SUDS.

**Role:** What role will the development play in terms of sustainability? Such as a neighbourhood focus, biodiversity, habitat creation, energy efficiency, equity/affordable housing. N/B it may have more than one role.

**Sustainability Principles:** Should be shaped by the context/site considerations. **ENSURE:**

- Safer streets and spaces.
- Quality of life and well-being.
- Accessible to all users (not just vehicles).
- Character, local distinctiveness/identity, green/blue infrastructure, habitat, recreation.

## Step 3

Detailed design work

### Design Concept

**Design Concept:** Use the appraisal process and site design principles to develop a 'design concept' to underpin the design approach to the scheme.

**Concept Diagram:** Initial design options should be expressed as a simple concept diagram or sketch to convey the key ideas about the proposal, illustrating the basic elements that will shape the scheme in terms of structure and character. (N/B this is not a detailed layout).

**Consider the Options:** Depending on the issues or scale of development it may be appropriate to draw up a number of options that consider the alternatives before reaching a preferred position.

**Reconcile Conflicts:** Where conflicts arise between issues, these should be explained and justified e.g. partial removal of a hedgerow required to create a direct link to local shops harms the hedgerow but has a positive benefit in terms of encouraging local journeys on foot.

**Initial Layouts/Design Work:** Should build upon the concept and site design principles.

#### Pre-application discussions:

**If you have not yet done so, it is at this stage you should approach the LPA for pre-application discussions - before proposals become too advanced and fixed. Supply draft materials.**



## 2.5 Context Appraisal (Step 1)

“Always design a thing by considering it in its next larger context - ...a room in a house, a house in an environment, an environment in a city plan.”

Eliell Sararinen, Finnish Architect and City Planner

### Useful Reference

The Landscape Character of Derbyshire

[www.derbyshire.gov.uk/environment/conservation/landscapecharacter](http://www.derbyshire.gov.uk/environment/conservation/landscapecharacter)

Landscape Character Assessment, Bassetlaw, Nottinghamshire (2009)

[www.nottinghamshire.gov.uk/home/environment/landimprovements/landscapecharacter](http://www.nottinghamshire.gov.uk/home/environment/landimprovements/landscapecharacter)

[www.helm.org.uk](http://www.helm.org.uk)  
Understanding Place: An Introduction (2010)

Understanding Place: Character and Context in local planning (2011)

Understanding Place: Historic Area Assessments: Principles and Practice (2010)

**2.5.1** To achieve development that is appropriate to its context first requires an examination and understanding of the wider area beyond the site boundary, as well as the site itself, by undertaking a context appraisal and site appraisal.

**2.5.2** The appreciation of context, including historic context (where applicable) resulting from these appraisals should generate creative design ideas for the site, identify positive opportunities to help ‘ground’ the development to the place, as well as highlight constraints or issues for resolution at an early stage in the design process. Where available, local studies such as conservation character appraisals and landscape character assessments can be useful references to help inform this approach.

**2.5.3** A summary of the key findings of the appraisals and evaluation should be evident in the Design and Access Statement. However, an appraisal is more than a simple description or photographic record of the surrounding area, but requires an **evaluation** and **explanation** of how they have informed and influenced the scheme. This is a critical stage, but one which is often overlooked.

### Character area images



1. Historic High Street



2. 19th Century artisan terraces



3. Victorian semi-detached villas



4. Post-war estate housing



5. Farm Hamlet



6. River valley (including the site)



**CHARACTER AREAS**

- 1 CONSERVATION AREA - Town centre  
Mixed uses: 2-3.5 storeys. Burgage plots - 18<sup>th</sup> - 19<sup>th</sup> C
- 2 19<sup>th</sup> C BY LAW ARTISAN TERRACES  
2 storey 30 dph narrow frontages
- 3 VICTORIAN SEMI-DETACHED VILLAS  
2 1/2 storey 50 dph steep pitched roofs
- 4 POST WAR (50-60s)  
2 storey 28 dph open frontages, road dominated
- 5 FARM + HAMLET  
2 storey + 3 st Georgian house (LB)  
Vernacular stone cottages & farmhouse + barns
- 6 RIVER VALLEY  
incl site  
slope to NW, steep @ W end. Pasture drystone walls  
Wooded riverbank  
Extensive floodplain. Hedgerows at lower levels

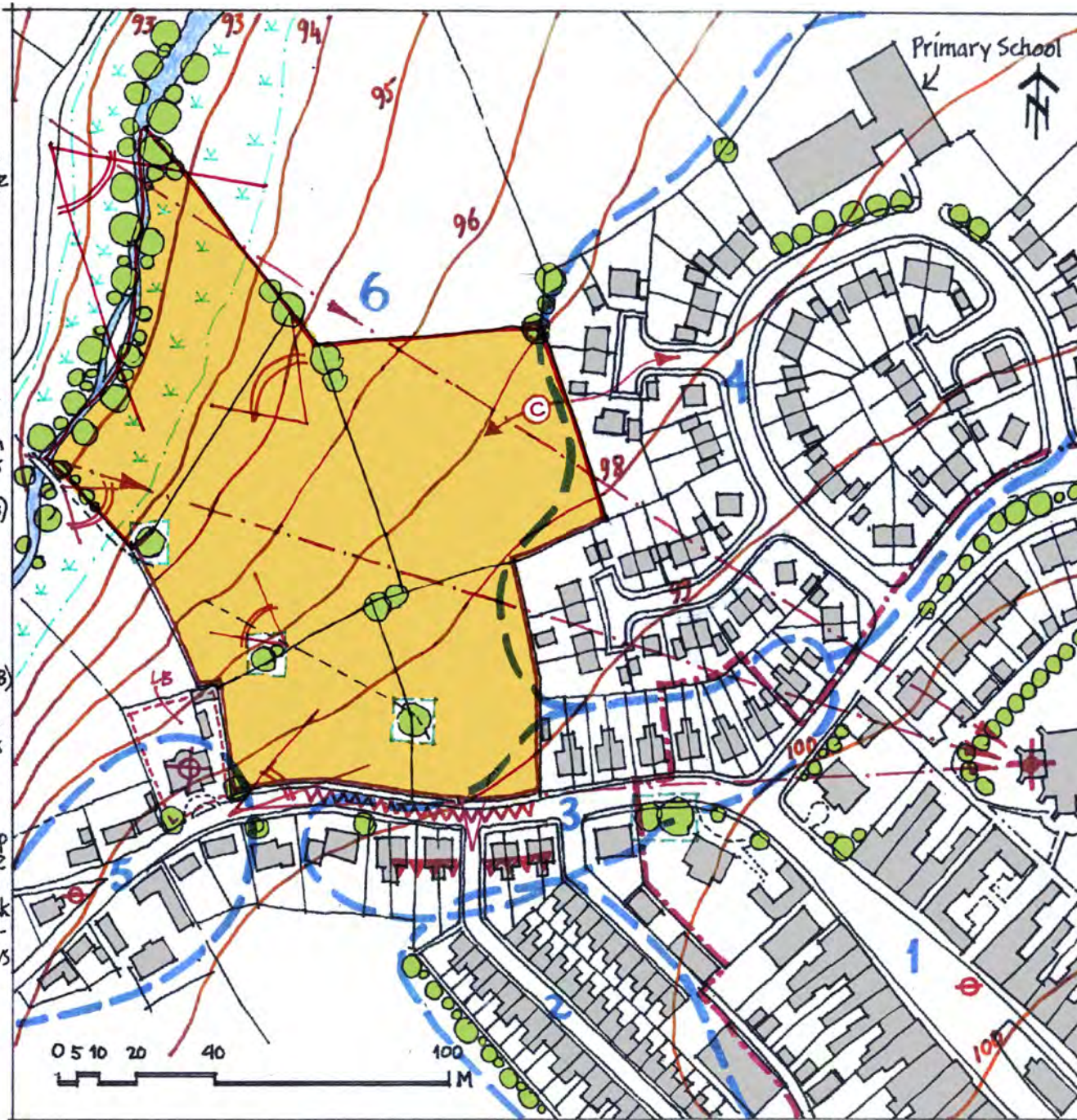

**DESIGN PROCESS  
STAGE 1  
CONTEXT APPRAISAL**

- EXG BUILT FORM SHOWN AS FIGURE GROUND TONE
- PANORAMIC VIEW TO & FROM SITE
- VIEW TO LANDMARK
- LANDMARK (CHURCH TOWER)
- LOCAL LANDMARK (LB)
- SKYLINE VISIBLE FROM RIVER VALLEY
- POTENTIAL PEDESRIAN CONNECTIVITY
- LISTED BUILDING & ITS CURTI-EGE
- TPO
- NARROW, BUSY MAIN ROAD
- CONSERVATION AREA
- SITE
- FLOOD PLAIN

## 2.6 Site Appraisal (Step 1)

**2.6.1** The site appraisal should look in detail at the existing conditions and characteristics of the development site and how it relates to its immediate and wider surroundings.

**2.6.2** A site appraisal diagram clearly illustrating the key site characteristics should be provided and used to inform the design.

**2.6.3** Considerations and characteristics will vary between sites but are likely to include:

### Key site considerations:

- Linkages to the wider area
- Existing entrances, desire lines and routes through the site
- Views into, across and out of the site
- Topography, levels, ground conditions and land instability
- Drainage issues and land liable to flood
- Heritage assets – listed buildings, conservation areas, archaeology as well as non-designated heritage assets
- Existing buildings and their potential for retention and incorporation into the scheme
- Landscape features - watercourses, trees, hedges and woodlands
- Potential ecology/wildlife habitats
- Orientation and micro-climate
- Orientation and views into/out of the site
- Boundary treatments and edge conditions
- Sensitive edges
- Amenity issues – light/privacy/noise/smell

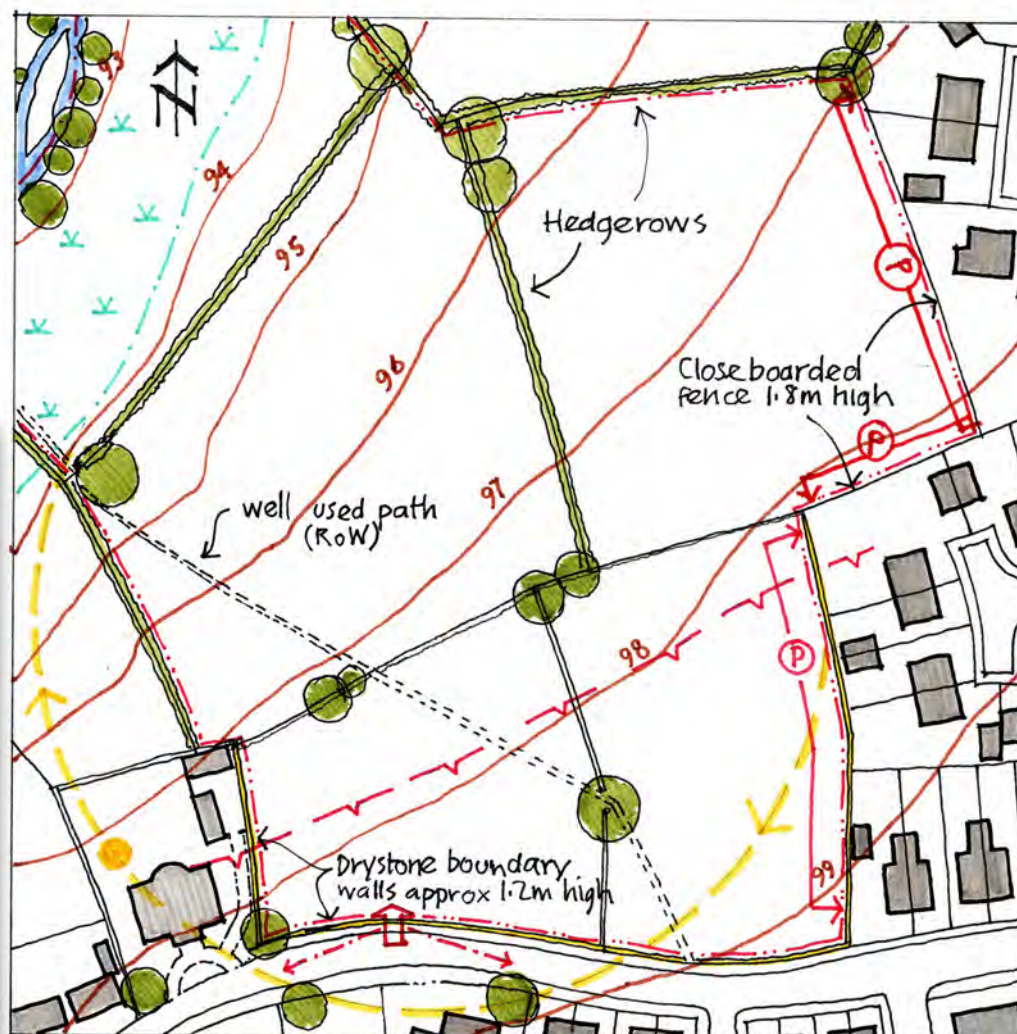

### DESIGN PROCESS STAGE 2 SITE APPRAISAL

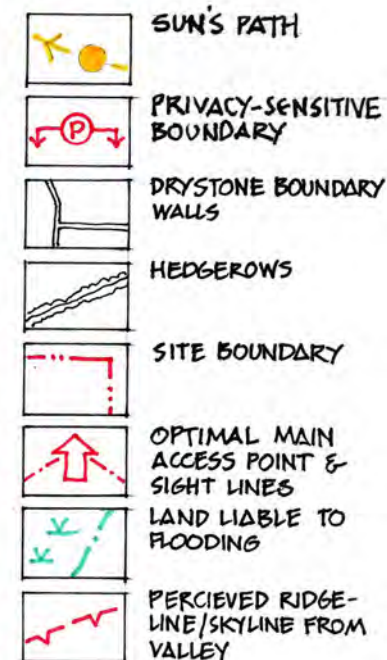

Above: The site appraisal should examine and understand the assets and constraints of the site. A thorough understanding of the site will reveal key issues and determine the area of developable land once these have been taken into account.



## 2.7 Design Principles and Concept (Steps 2 & 3)

**2.7.1** The site appraisal process provides an understanding of the site to inform the design process. This should establish design and sustainability principles around which the scheme will be developed e.g. key buildings and frontages, focal points, views in and out, main routes/connections etc.

**2.7.2** Positive features should, wherever possible, be retained and incorporated into the scheme, to connect it to the place and strengthen its distinctiveness.

**2.7.3** Initial design options should first be explored and expressed in the form of a simple concept diagram or sketch to convey the key ideas about the proposal, illustrating the elements that shape the form and layout of the scheme; N/B this is not a detailed layout.

**2.7.4** It will often be appropriate to look at a range of potential development options and consider the alternatives, not just focus on the first idea. This may require reconciling conflicting issues. Where such conflicts occur this should be explained and justified as part of the Design and Access Statement.

**2.7.5** This stage of the process is an appropriate point at which to approach the local planning authority to discuss the design approach, prior to the development of detailed layouts and plans.

**2.7.6** Depending on the scale, nature and sensitivity of the proposal the developer may be advised to consult with the community before progressing to a more detailed design.



### DESIGN PROCESS STAGE 3

#### DESIGN CONCEPT

	BUILDING FRONTAGE
	KEY BUILDING FRONTAGE
	FLAT/S OVER GARAGES etc
	IMPORTANT WALL OVER 1.5m high
	GREENSPACE
	SUDS/SWALE
	NEW TREE PLANTING
	PARKING COURTYARD
	TERMINATED VIEW
	SENSE OF PLACE / FOCAL PLACE
	DEFLECTED VIEW
	FOCAL BUILDING
	CONTINUITY OF ESTABLISHED BUILDING LINE

Above: The design concept diagram should underpin the scheme and establish the design parameters and principles that will shape and inform the design approach to the development.

## 2.8 Preparing Your Application

### 2.8.1 Design and Access Statements

To support the delivery of good design, Design and Access Statements (DAS) are now required to accompany most applications for development.

**2.8.2** They must set out the design rationale behind an application, explain how it has responded to local context and how it addresses crime and disorder and the fear of crime. The information gathered through the context appraisal and site appraisal stages and the development of a design concept should all be incorporated within the DAS to demonstrate a reasoned approach to the development and how the scheme has evolved.

**2.8.3** This tool is often underused or dealt with as an afterthought. Rather, the DAS represents an opportunity to present schemes positively and demonstrate that proposals are underpinned by a sound design concept based on an understanding of the place.

**2.8.4** However, they are only as useful as the quality of information that goes into them. The inclusion of diagrams, annotated drawings, sketches, cross sections, maps, and photos to illustrate the proposals, will greatly increase the understanding of a scheme far better than pages of detailed text.

**2.8.5** Where appropriate, the local planning authority will 'fix' important details or principles identified within the DAS to a planning permission, using conditions to ensure that any key elements are binding. It is therefore an important document and its preparation should begin at an early stage rather than written post-design to justify a pre-determined scheme.

### 2.8.6 The Development Team Approach

Where appropriate and feasible the local planning authority will adopt a development team approach for managing proposals for residential development. An appointed officer will coordinate with the appropriate departments and partners. This will draw on both the Council's own in-house expertise but could also include external organisations such as the County Council, Environment Agency, English Heritage, Police Crime and Design Advisor, Natural England and others as appropriate.

**2.8.7** The nature of the development team will be adjusted to reflect the scale, complexity or sensitivity of the proposal or other relevant issues.

### 2.8.8 Pre-application discussions

To assist in the planning application process developers are encouraged to discuss their proposals with the local planning authority at the pre-application stage. This will help identify any planning issues early on, so these can be addressed. Sufficient

time should be allowed to enable any such issues to be resolved prior to the submission of a planning application.

**2.8.9** The guidance in this document should be followed closely to ensure that sufficient consideration has been given to the context and the appropriateness of the scheme to a particular site before entering into discussions. At this preliminary stage, it would be unwise to have developed the design beyond concept diagrams.

**2.8.10** The context and site appraisal work should form the basis of a dialogue with the local planning authority, to agree the issues to be addressed and establish the design principles by which the site should be developed. Subsequent design work should then be informed by the appraisals and agreed design principles.

#### NOTE:

Pre-application submissions comprising only detailed layouts may be returned and the applicant advised to undertake the context and site appraisal stages before progressing further.

#### Useful Reference



Design and Access Statements: How to read, write and use them, Cabe, 2007





**2.8.11** In order to maximise the benefit of pre-application discussions, as part of the initial approach the developer will be expected to provide the following information:

**A site appraisal plan:**

Identifying the location of the site within its wider setting, identifying existing areas of character, showing how it connects with and relates to adjoining parts of the settlement, character, local centres, transport, services, views, local geography etc - see 2.6;

**A site analysis plan:**

Showing an understanding of the site characteristics [constraints and assets] - see 2.7; and

**A concept sketch/diagram:**

To illustrate the abstract idea and communicate the key design principles by which the site is proposed to be developed - see 2.8.

**(NOTE: *this is not a detailed design layout at this stage*).**

## 2.9 Benchmarks and Review Processes

**2.9.1** The design quality of proposals for residential development will be assessed using a number of methods. These may vary according to the nature of a particular development. However, the review processes will provide the benchmarks against which a scheme will be judged on design grounds. They will include:

**2.9.2 Design Consultation:** Where the service is available, the Urban Design Officer or equivalent, will be consulted on proposals for residential development and will provide a design consultation response. This will provide an opinion on the acceptability of the design aspects of the scheme. This may also be accompanied by, or in the form of a Building for Life 12 appraisal (see 2.9.7 below).

**2.9.3 Regional Design Panel:** Some schemes may be requested to be referred to the East Midlands Regional Design Panel, known as OPUN. Typically these may include large scale developments, or those of a strategic or particularly sensitive nature, although any scheme could potentially be referred if this is considered to be appropriate.

**2.9.4** Applicants whose schemes are referred will normally be requested to attend a design meeting and to present their proposals to the review panel. The panel's comments will be used to inform the progression and refinement of the scheme.

**2.9.5** Schemes may be referred to OPUN at the pre-application stage and in many cases this will be preferable before the design of a proposal becomes too advanced or fixed. There is normally a charge for this service.

**2.9.6 Local Review:** The partner authorities will engage in a local quality review process. This will involve referring selected proposals for residential development to an internal review group comprising of officers from each local planning authority. The group will undertake a design review of each case. This will also serve as a benchmarking process to assess how each Council is applying and using the Guide and to check for consistency of approach and allow for ideas and suggestions to be exchanged.

**2.9.7 Building for Life 12 (BfL12):** Is a national standard for well-designed homes and neighbourhoods and is about creating good places to live. Proposals are assessed against 12 questions under three headings:

- **Integrating into the neighbourhood**
- **Creating a place**
- **Street and home**

The 12 questions reflect a vision for what new housing developments should be; Attractive, functional, sustainable places.

**2.9.8** Building for Life 12 is not an end in itself, but a tool for assessing how well schemes for residential development meet the requirements of local design policies. It forms a framework for design discussions between the stakeholders and provides a measure of the design performance of a scheme which can be used to assist in the decision making process.

**2.9.9** BfL12 uses a traffic light system to determine whether schemes are well designed and identify areas that may require improvement. It is recommended that schemes achieve as many greens as possible. Greens indicate that a scheme is well designed in relation to a particular question. Ambers should be minimised and indicate the need to rethink whether an element can be improved in order to convert it to a green. Red lights should be avoided and give a warning that an aspect of the scheme needs to be reconsidered.

**2.9.10** Where possible, the Design and Access Statement (DAS) should be used to assist in this process e.g. it could be structured according to the BfL12 questions (provided all the requirements of a DAS are addressed).



Building for Life 12 is designed to be a collaborative tool that engages the key stakeholders and lead to better outcomes

## Building for Life 12 questions

### Integrating into the neighbourhood

#### 1. Connections

Does the scheme integrate into its surroundings by reinforcing existing connections and creating new ones; whilst also respecting existing buildings and land uses along the boundaries of the development site?

#### 2. Facilities and services

Does the development provide (or is it close to) community facilities, such as shops, schools, workplaces, parks, play areas, pubs or cafes?

#### 3. Public transport

Does the scheme have good access to public transport to help reduce car dependency?

#### 4. Meeting local housing requirements

Does the development have a mix of housing types and tenures that suit local requirements?





## Creating a place

### 5. Character

Does the scheme create a place with a locally inspired or otherwise distinctive character?

### 6. Working with the site and its context

Does the scheme take advantage of existing topography, landscape features (including water courses), wildlife habitats, existing buildings, site orientation and micro-climates?

### 7. Creating well defined streets and spaces

Are buildings designed and positioned with landscaping to define and enhance streets and spaces and are buildings designed to turn street corners well?

### 8. Easy to find your way around

Is the scheme designed to make it easy to find your way round?

## Street & Home

### 9 Streets for all

Are streets designed in a way that encourage low vehicle speeds and allow them to function as social spaces?

### 10 Car parking

Is resident and visitor parking sufficient and well integrated so that it does not dominate the street?

### 11 Public and private spaces

Will public and private spaces be clearly defined and designed to be attractive, well managed and safe?

### 12 External storage and amenity space

Is there adequate external storage space for bins and recycling as well as vehicles and cycles?



Useful Reference



Building for Life 12: The sign of a good place to live

Cabe at the Design Council, Home Builders Federation, Design for Homes (2012)



---

# PLACE MAKING PRINCIPLES

## Good Urban Design Practice

---

*“The delivery of a well-designed environment, by which one might mean simply one that is sustainable, livable and fulfilling, is dependent on getting the framework for the... settlement right across all its scales.”*

Matthew Carmona Professor of Planning and Urban Design at the Bartlett School of Planning, UCL.

- |  |                                 |                             |
|--|---------------------------------|-----------------------------|
| <b>3.1</b> Places for People             | <b>3.8</b> Parking              | <b>3.15</b> Enclosure       |
| <b>3.2</b> Movement                      | <b>3.9</b> Street Design        | <b>3.16</b> Building Design |
| <b>3.3</b> Green and Blue Infrastructure | <b>3.10</b> Public Realm Design | <b>3.17</b> Adaptability    |
| <b>3.4</b> Townscape                     | <b>3.11</b> Amenity             | <b>3.18</b> Materials       |
| <b>3.5</b> Character                     | <b>3.12</b> Place Hierarchy     | <b>3.19</b> Servicing       |
| <b>3.6</b> Layout                        | <b>3.13</b> Design for Corners  |                             |
| <b>3.7</b> Block Structure               | <b>3.14</b> Frontages           |                             |
-

# How to use Part 03 of this guide

Part 03 of this guidance sets out the specific design guidelines, in the form of 'place making principles', that should be followed in order to achieve good quality 'successful places'. This page outlines the general layout of each principle and indicates how this should be used to inform the design.

**Applicable scale** - this symbol highlights and identifies the scales of development at which the objective and best practice principle would be most likely to be applicable N/B it may apply at a number of scales

**Building for Life 12 (BfL12)** - relevant BfL12 questions are set out next to each Design Principle

**Margin** - includes helpful information including relevant quotes, references, good practice and steps that could enhance its sustainability

**Logos** - indicate the type of information within the margin



**Design Principle** - title of the design principle/section to be addressed by the design of the development

**Place making principle** - that should be met by the development in support of the Design Principle (N/B there may be more than one principle per section)

**Bullet point criteria** - identify what measures relating to the best practice principle should be used to achieve better design and make successful places

**3.4 Townscape**

**3.4.1 Townscape**

*All schemes should create places that make a positive addition to the built environment in terms of its townscape and visual interest. Development should 'give something back' to the place in which it is being built.*

**3.4.2** Designing townscape is the art of relating buildings to each other and the spaces and other elements around them, such as landscape, paving etc. It is the skill of arranging all the elements of the environment to compose an urban scene in a way that creates a pleasing relationship between the built form and open spaces, that are also fit for purpose.

**3.4.3** All new development will contribute to the townscape of the place in which it is built, simply by its presence in a street or neighbourhood. However, it is its design and how it is put into practice that will determine whether or not a development adds positively to the richness and interest of the townscape.

**3.4.4** Often the places we find most interesting have developed incrementally providing layers of texture and form

**Successful places:**

- Contribute positively to the richness and interest of the settlement to foster a sense of place by applying the good urban design practice principles (places not estates).
- Respond to the individuality of places in respect of local characteristics such as building forms, materials, traditions, street patterns and spaces to inform the approach to the design.
- Establish a clear urban structure within the built form, streets and spaces.
- Use the relationship (juxtaposition) of buildings, streets and spaces to form varied and interesting townscapes and a sense of identity.

*Below: An example of a distinctive place where a mature tree and small green form a focal point. Elevations are well proportioned and windows are arranged to form a sense of enclosure, while materials and details combine to create a positive real sense of townscape*

**3.4.6** Considering the development as a three dimensional composition enables the designer to carefully integrate the different elements of the built environment as a coherent design. The example shows how:

- The entrance is narrowed to create a pinch point, signalling drivers to slow upon entering the site and encourages vehicles to emerge with caution.
- The buildings have been arranged to define the edges of a space, provide continuity and create a strong sense of enclosure.
- Buildings are outward looking with windows orientated to overlook the street, providing safety and security.
- A larger building is positioned deliberately on the axis of the street to provide a focal point and 'terminate' or 'close' the view from the entrance.
- Roof heights (eaves and ridge) and roof forms, together with chimneys and dormers, add visual interest to the skyline.
- Street trees provide vertical division of the space, shading, soften its appearance and increase its visual appeal.
- Hard surfacing provides horizontal sub-division of the space, visually prompts drivers to slow down and delineate areas of on-street parking.
- The 'cranked' building uses the built form to deflect a view into a rear courtyard, which itself incorporates a feature focal point tree.

**Text** - expands the key issues and explains the requirements of the place making principle

**Images** - show examples of real places to demonstrate how the best practice principle has been implemented on the ground or occasionally to illustrate examples of poor practice to be avoided

**Drawings** - illustrate and support the key aspects of the best practice principle, providing indicative examples of how this can be implemented

36

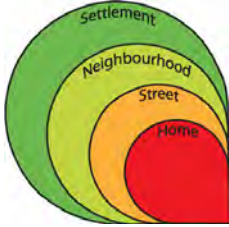

## 3.1 Places for people

**3.1.1** The quality of the place where we live has a major influence on our quality of life. The place making process is about creating great places where people will want to live, work, visit and enjoy.

**3.1.2** This is not merely a matter of architecture (although this is one factor). Rather, it combines all the elements of the physical environment (streets, spaces, landscape and built form) in an integrated design. This requires a good understanding of the place, how it works and the ability to recognise and harness the opportunities available to make successful places.

**3.1.3** However, it should also be recognised that successful places are not just built, but they develop and flourish over time. The actual process of creating the physical place is only one, albeit very important, aspect of the challenge. By making the right design choices from the outset, the creation of a good built form can provide the foundation on which vibrant and sustainable communities can grow.

**3.1.4** Part 03 of this SPD establishes the key place making principles. These provide the basic ingredients needed for the creation of successful places. Each principle is accompanied by explanations and criteria that outline how successful places address or fulfil these

requirements.

**3.1.5** In order to meet the quality of development that is expected, proposals must show how they will create a successful place by meeting the requirements of the principles and their accompanying criteria.

**3.1.6** The extent to which a development will need to apply these principles will vary according to the scale, complexity and sensitivity of the scheme. However, it will be expected that applicants must demonstrate how their proposals have had regard to the design process and responded to the relevant principles in this SPD. Our aim is to ensure all new developments are *successful places*.

**Below and right:** Examples of well designed recent contemporary residential schemes that create places for people and demonstrate what can be achieved with a considered design-led approach to development



“...we have simply lost the art of place making... We are good at putting up buildings but we are bad at making places.”

Bernard Hunt, HTA Architects

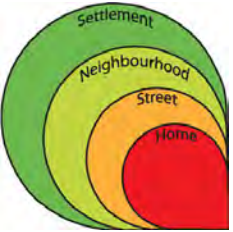

**Building for Life** criteria

**Integrating into the neighbourhood**

**1. Connections** Does the scheme integrate into its surroundings by re-inforcing existing connections and creating new ones; whilst also respecting existing buildings and land uses along the boundaries of the development site?

**2. Facilities and services** Does the development provide (or is it close to) community facilities, such as shops, schools, workplaces, parks, play areas, pubs or cafes?

**3. Public transport** Does the scheme have good access to public transport to help reduce car dependency?

**Creating a place**

**6. Working with the site and its context** Does the scheme take advantage of existing topography, landscape features (including water courses), wildlife habitats, existing buildings, site orientation and micro-climates?

**8. Easy to find your way around** Is the scheme designed to make it easy to find your way round?

**Street & Home**

**9 Streets for all** Are streets designed in a way that encourage low vehicle speeds and allow them to function as social spaces?

## 3.2 Movement

### 3.2.1 A balanced approach to movement

*Proposals must take a balanced approach to movement and provide for the needs of all users (including pedestrians, cyclists and those with impaired mobility) of the streets and spaces not just the needs of vehicles*

**3.2.2** The movement network provides the skeletal framework around which the development can be formed. The early design choices are therefore critical to putting in place a well reasoned and practical movement network that meets the needs of all its users. This means ensuring that one group's requirements do not dominate to the extent that they constrain or are detrimental to needs of other groups.

**3.2.3** Equitable access throughout a development means providing users with a real choice of movement, so they can choose their own route and mode of transport. Short local trips provide the best opportunities for journeys on foot or bicycle (active travel) so these routes should be more direct than those for cars.

**Successful places:**

- Recognise and accommodate the needs of pedestrians, cyclists, public transport users and other vehicles.
- Provide movement networks that encourage walking and cycling as the primary modes of travel for local trips making it easy to choose active travel or access public transport.
- Locate bus stops within a reasonable walking distance (normally 400m), via safe routes and provide bus shelters to encourage their use.
- Provide for access by motor vehicles and accommodate the size and frequency of service vehicles without detracting from the quality of the environment.



A safe footpath provides a broad, overlooked and convenient route connecting with the adjoining area

### 3.2.4 Connected, integrated, permeable

*Proposals should comprise a layout of permeable streets that connect to and integrate with the surrounding network of streets and paths*

**3.2.5** Connecting developments with the surrounding streets and neighbourhoods allows them to physically integrate with and function as part of the established settlement, both socially and economically.

**3.2.6** Developments with poor connections to adjoining areas and movement networks designed around the car result in insular, disconnected places that fail to integrate with the settlement and which reduce the inclination to walk, cycle or use public transport.

**3.2.7** Conversely, integrated permeable movement networks are beneficial to both communities and help reduce car dependency. They encourage active travel by being easier to navigate and minimising walking distances to nearby facilities, which increases their pedestrian and cycle catchments.

**Sustainable?**

How does the design influence how people choose to travel? Does it provide transport choices that reduce car dependence and encourage active travel? Active journeys have many benefits:

- Reduced energy use and emissions from transport.
- Increased interaction fostering social networks and a sense of community.
- Health benefits; and
- Making places feel safer - more people being out and about.

“...it is an instinctive and continuous habit of the body to relate itself to the environment, this sense of position cannot be ignored.”

Gordon Cullen, Townscape

**Useful References**

Manual for Streets (2007)

Safer Places: The Planning System and Crime Prevention (2004), ODPM/Home Office

**Successful places:**

- Have internal permeability with interconnected streets that allow people to choose the most convenient and direct option for their journey.
- Make connections to the adjacent street and footpath network, including safe, direct pedestrian/cycle links.
- Design the movement network to connect easily to local destinations by following desire lines to where people want to go.

**3.2.8 Legibility**

*Places should be easy to understand and navigate so people can find their way around without difficulty*

**3.2.9** Making places legible is to make them easy to understand and navigate, so that people have a clear mental image of the place. They should include recognisable features that help give them a sense of place and make them memorable.

**3.2.10** Memorable spaces may contain a focal point such as a piece of public art or a mature tree. Key nodal points may comprise one or more main routes that coincide with the provision of a distinctive public space, containing a notable landmark building.

**3.2.11** Often, two or more of these elements will need to be considered in combination to design effective legible environments e.g. designing a view towards a landmark or building that acts as a focal point or terminating feature, helps to create a sense of place.

**3.2.12** Thresholds to private areas such as courtyards should use devices such as changes in surface, pillars, access through an archway etc. to define the extent of the defensible space. Psychologically, this gives the impression that the area beyond is private.

**Successful places:**

- Contain landmarks, such as important buildings, distinctive public spaces, public art, mature trees and views to these features.
- Distinguish important nodal points or junctions with distinctive spaces, often associated with activity and movement.
- Incorporate movement along conspicuous routes and edges and that are easy to recognise and follow, such as main roads or defined streets.



A mature tree, distinctive building and a public space create a memorable location giving legibility to this place



Public art can aid legibility, making places more memorable



A strong corner on a main route reinforce its legibility

**Good Practice**

Pedestrians and cyclists should normally be accommodated within the street.

Where segregated routes are considered necessary they can be acceptable if they are well designed. Regardless of length, such routes should be:

- As straight and direct as possible.
- Be well lit.
- Wide enough to avoid conflicts between pedestrians and cyclists (where shared) or allow people to pass one another comfortably.
- Overlooked by surrounding buildings and activities.
- Attractively designed and landscaped.
- Devoid of hiding places.

**Good Practice**

A *Ped shed* (pedestrian shed) is a walkable catchment and is the basic component of a walkable neighbourhood.

They are often defined as the area that can be covered by 5 or 10-minute walk or 400-800m in distance.

**3.2.13 Safer neighbourhoods**

*The movement network should be designed to create a safe and comfortable environment for users*

**3.2.14** Routes should be clear, direct and attractive places where people feel comfortable. If they are cramped, poorly overlooked, indirect or unwelcoming they can attract crime or anti-social behaviour and discourage legitimate users.

**Successful places:**

- Create active streets that are easy for people to find their way around and that link to local destinations.
- Are well lit and overlooked by surrounding buildings and uses to provide a sense of natural surveillance and safety.
- Demonstrate clear definition between public and private spaces.
- Provide for pedestrians, cyclists and vehicles within the same space, without them being segregated.
- Avoid networks of separate footpaths and unsupervised areas, including public footpaths that run to rear of and provide access to properties, for reasons of safety and security.

**3.2.15 Walkable neighbourhoods**

*Proposals should seek to create walkable neighbourhoods that provide for or are located within easy walking distance of local facilities*

**3.2.16** A walkable neighbourhood is a residential or mixed area with a range of everyday facilities within an approximate 10 minute (800m) walking distance. Some facilities command greater catchments although these become less accessible on foot with increased distance.

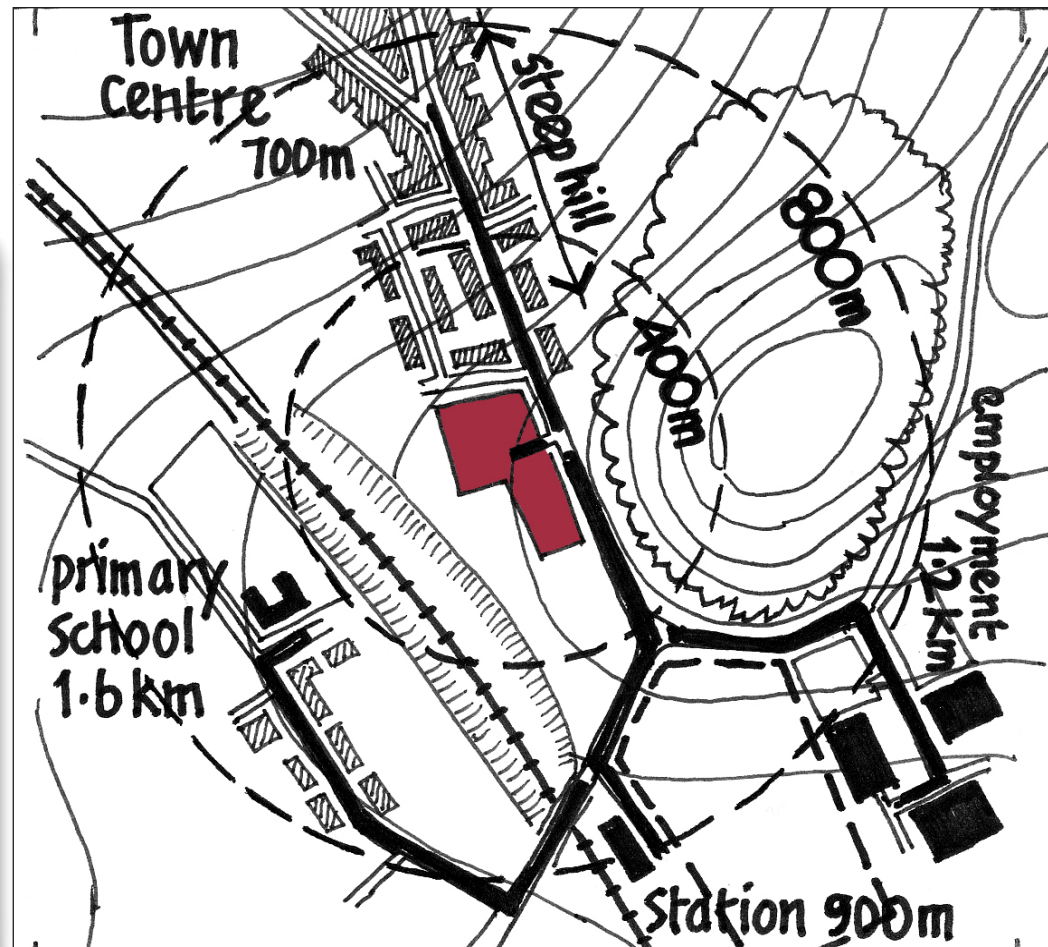

True walkable catchments are irregular (not circles) because they cover the actual route not as the crow flies. The distance walked is often further than is suggested by the standard ped shed circle.



Sustainable?

What is a reasonable walking distance?

400m is a reasonable walking distance to a bus stop (approx 5 minutes).

800m is a walkable distance to a town or local centre (approx 10 minutes).

The average walking journey is 1km. Not many people walk more than 2km.

However, actual walking distances may be reduced according to various factors.

Proposals must take account of steep gradients, the bendiness of the route and psychological factors such as barriers like how easy or difficult it might be to cross busy roads, real or perceived fear of crime and personal safety. If routes are indirect the actual walking distance is reduced.

Shaping Neighbourhoods, Barton *et al*

#### Useful Reference

Shaping Neighbourhoods, Barton *et al*, (2010)

**3.2.17** Catchment distances diagram shows typical desirable and possible maximum thresholds for walking to facilities at local, neighbourhood/village and settlement/town level.

**3.2.18** It is reasonable to expect some types of facilities, such as a children's playground, within a short walking distance of a residential area, whereas people are prepared to walk further to reach other key facilities such as a local centre or a school.

**3.2.19** These distances are a starting point for discussion. In more rural settings greater distances to more significant facilities (e.g. leisure centre, FE College etc.) are to be expected.

**3.2.20** Accessibility criteria should also have regard to a range of local factors:

- The catchment populations of different facilities.
- The degree of permeability/directness of walking/cycle routes.
- The general shape of the settlement.
- The propensity of users to walk to specific facilities.
- The influence of topography.
- The safety of the route (real or perceived fear of crime).
- The level of hostility in terms of traffic speed and volume and the quality of the pedestrian experience.

#### Indicative catchments:

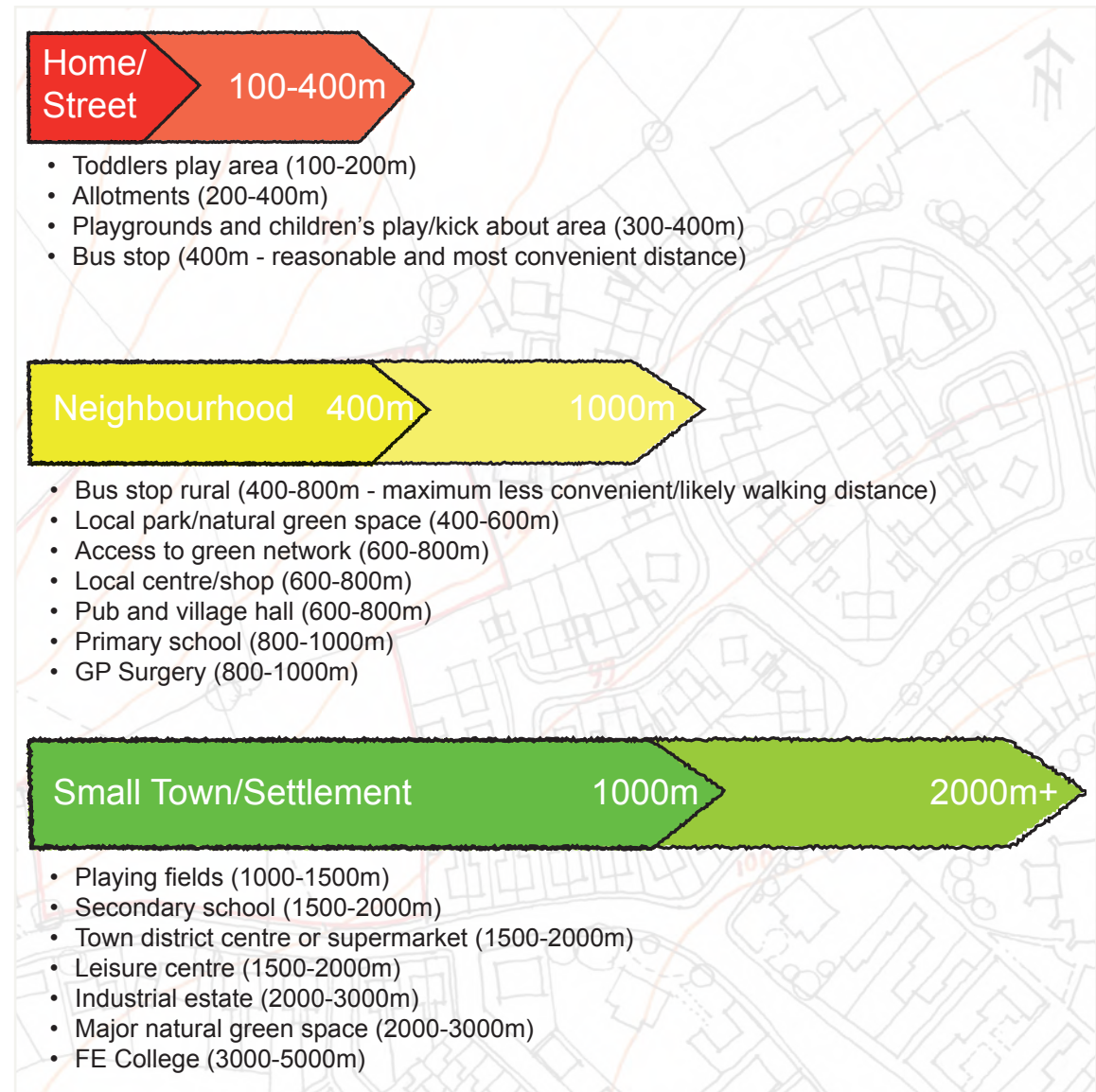

Source: Adapted from Barton *et al*, Shaping Neighbourhoods, 2010

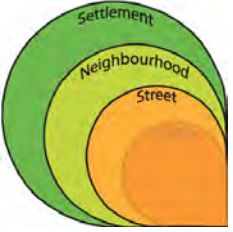

**Building for Life** criteria

**Integrating into the neighbourhood**

**1. Connections** Does the scheme integrate into its surroundings by reinforcing existing connections and creating new ones; whilst also respecting existing buildings and land uses along the boundaries of the development site?

**Creating a place**

**5. Character** Does the scheme create a place with a locally inspired or otherwise distinctive character?

**6. Working with the site and its context** Does the scheme take advantage of existing topography, landscape features (including water courses), wildlife habitats, existing buildings, site orientation and micro-climates?

**Street & Home**

**11 Public and private spaces**

Will public and private spaces be clearly defined and designed to be attractive, well managed and safe?

**Useful Reference**



*Biodiversity by Design*, Town and Country Planning Association

The Landscape Character of Derbyshire, Derbyshire County Council

Landscape Character Assessment, Bassetlaw, Nottinghamshire (2009)

## 3.3 Green and Blue Infrastructure

### 3.3.1 Green and Blue Infrastructure

*Proposals should integrate green and blue infrastructure into the development layout wherever possible*

**3.3.2** Green and blue infrastructure refers to the network of existing or new, natural and managed green spaces and water bodies, together with the linkages that join up individual areas as part of a wider network of green spaces, such as footpaths, cycle paths and bridleways.

**3.3.3** It provides many benefits, including:

**Good Health** - Greenery promotes health, well-being and enhances quality of life.

**Recreation** - Formal and informal spaces provide places for exercise and relaxation.

**Livable places** - Green networks can add distinctiveness, a positive outlook or buffer negative features. They can also protect the setting of heritage assets and aid the interpretation of assets such as archaeology.

**Movement** - Pleasant recreational routes that link to adjoining green spaces.

**Environment** - Influence local micro climate and air quality, providing shade, shelter,

absorbing CO<sub>2</sub>, pollutants etc.

**Water Management** - green networks able to form part of sustainable urban drainage systems (SUDS).

**Ecological Value** - through the creation of habitats that support biodiversity.

**Local Food Production** - through provision of allotments, fruit trees/orchards, community gardens etc.

**3.3.4** Green and blue infrastructure should be an integral aspect of the layout planning and structuring of any housing development wherever opportunities allow. This means retaining and incorporating natural assets such as mature trees, hedgerows or watercourses, as key features of the layout, if appropriate, or create new ones.

**3.3.5** Emphasis is also placed on spaces being multi-functional e.g. a SUDS with swales and ponds can enhance the character of a development, have biodiversity and landscape value and be part of a network of recreational routes.

**Below:** A multifunctional space includes a path and SUDS pond, to form an attractive outlook for the adjoining homes



**3.3.6** In all cases proposals should forge links with the wider network of green spaces whenever opportunities allow.

**Successful places:**

- Integrate existing green and blue features into their design/layout or create new ones.
- Connect with the existing wider green and blue infrastructure network.
- Create multi-functional green and blue spaces and routes.



**Above:** A SUDS channel with both ecological and amenity value

A retained mature tree has biodiversity value and provides a positive focal point



Balancing ponds slow water run-off and provide a positive outlook



A retained wood is a landscape buffer and shelter belt



Allotments potential/ local food production



(c) Crown Copyright and database right (2013). Ordnance Survey (100019526).

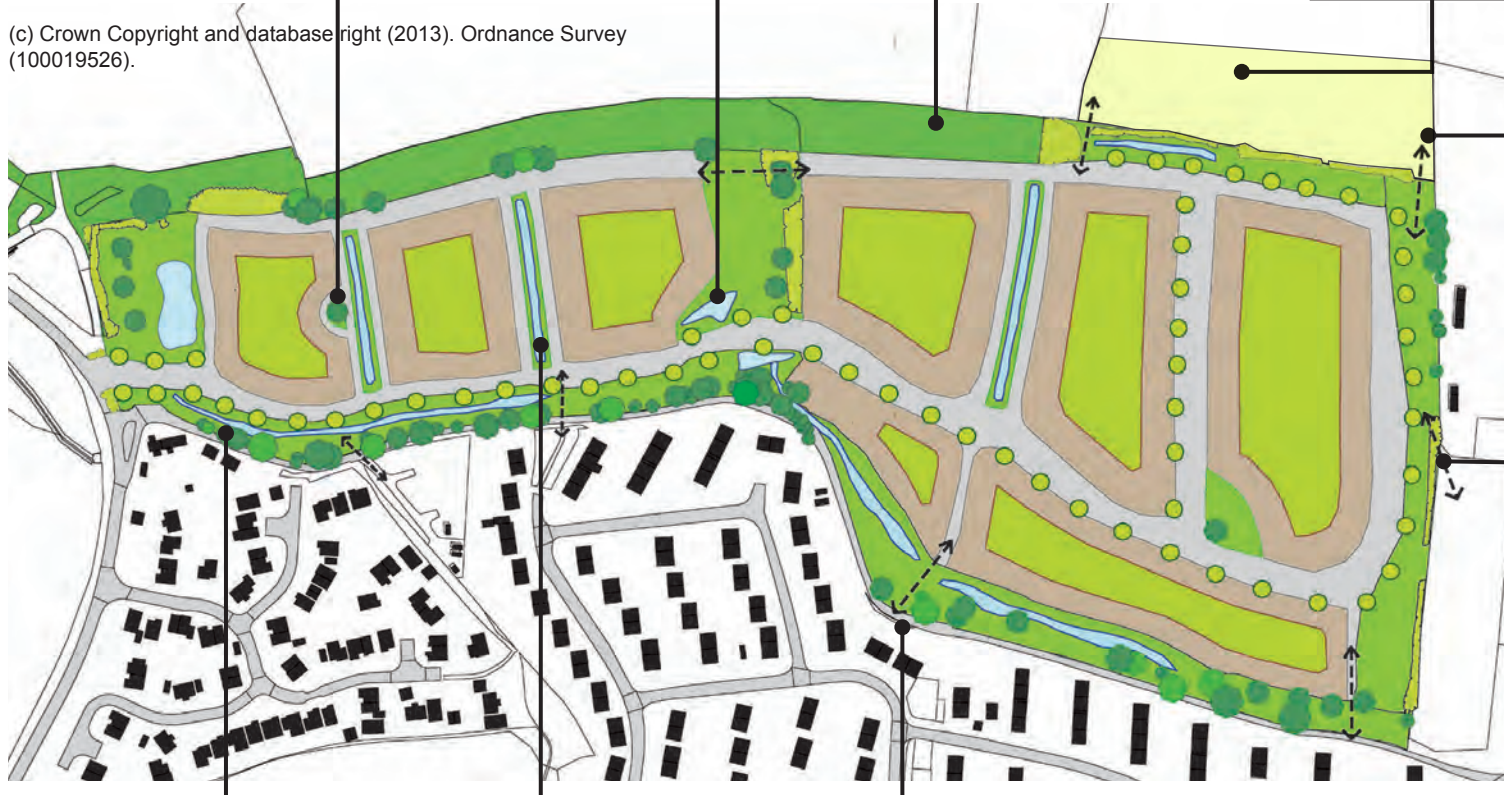

Footpaths integrated into the layout connect to wider countryside and network of recreational routes.



SUDS swales in a green corridor

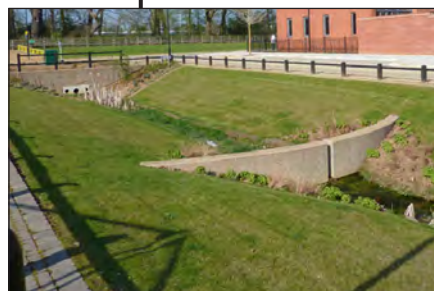

Swales integrated into the street layout

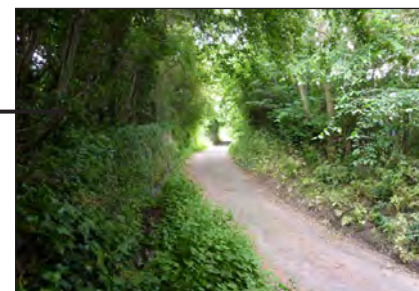

A characterful sunken lane is retained with new connections to form multi-user path

**3.3.7** An edge of settlement development that fully integrates a network of green and blue infrastructure into its layout. Existing positive natural features have been retained and incorporated wherever possible. New green elements (swales/ponds, street trees, green spaces/corridors etc) are multifunctional features, forge links with the surrounding area and add value.

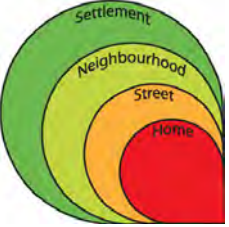

**Building for Life** criteria

**Integrating into the neighbourhood**

**1. Connections** Does the scheme integrate into its surroundings by reinforcing existing connections and creating new ones; whilst also respecting existing buildings and land uses along the boundaries of the development site?

**Creating a place**

**5. Character** Does the scheme create a place with a locally inspired or otherwise distinctive character?

**6. Working with the site and its context** Does the scheme take advantage of existing topography, landscape features (including water courses), wildlife habitats, existing buildings, site orientation and micro-climates?

**7. Creating well defined streets and spaces** Are buildings designed and positioned with landscaping to define and enhance streets and spaces and are buildings designed to turn street corners well?

**8. Easy to find your way around** Is the scheme designed to make it easy to find your way round?

**Street & Home**

**10 Car parking** Is resident and visitor parking sufficient and well integrated so that it does not dominate the street?

## 3.4 Townscape

### 3.4.1 Townscape

*All schemes should create places that make a positive addition to the built environment in terms of its townscape and visual interest. Development should 'give something back' to the place in which it is being built.*

**3.4.2** Designing townscape is the art of relating buildings to each other and the spaces and other elements around them, such as landscape, paving etc. It is the skill of arranging all the elements of the environment to compose an urban scene in a way that creates a pleasing relationship between the built form and open spaces, that are also fit for purpose.

**3.4.3** All new development will contribute to the townscape of the place in which it is built, simply by its presence in a street or neighbourhood. However, it is its design and how it is put into practice that will determine whether or not a development adds positively to the richness and interest of the townscape.

**3.4.4** Often the places we find most interesting have developed incrementally providing layers of texture and form

that while sometimes haphazard, combine to create attractive townscapes. Occasionally, a carefully planned scheme may exhibit similar qualities. However, the art of townscape is frequently undermined by the standardisation of housing with an emphasis on utility, economy and function, limiting the potential for incidental occurrences to stimulate, surprise or delight. Often the result is monotonous and uninteresting.

**3.4.5** It should be the aim of those involved in the development process to ensure that the design of their proposals creates new townscape that is a meaningful and worthy addition to the settlement.

**Below:** An example of a distinctive place where a mature tree and small green form a focal point. Elevations are well proportioned and homes are arranged to form a sense of enclosure, while materials and details combine to create a positive new area of townscape.



**Successful places:**

- Contribute positively to the richness and interest of the settlement to foster a sense of place by applying the good urban design practice principles (places not estates).
- Respond to the individuality of places in respect of local characteristics such as building forms, materials, traditions, street patterns and spaces to inform the approach to the design.
- Establish a clear urban structure within the built form, streets and spaces.
- Use the relationship (juxtaposition) of buildings, streets and spaces to form varied and interesting townscapes and a sense of identity.

“  
...bring buildings together and collectively they can give visual pleasure which none can give separately.

One building standing alone... is experienced as a work of architecture, but bring half a dozen buildings together and an art other than architecture is made possible.”

Gorden Cullen, Townscape



A street designed around townscape principles, creating enclosure of space with well defined edges, a key view terminated by a building that is sited and designed for this purpose and external materials of quality that reinforce the local distinctiveness of the area.

“  
...there is an art of relationship just as there is an art of architecture. Its purpose is to take all the elements that go to create the environment... and weave them together in such a way that drama is released.

Gorden Cullen, Townscape”

**3.4.6** Considering the development as a three dimensional composition enables the designer to carefully integrate the different elements of the built environment as a coherent design. The example shows how:

- The entrance is narrowed to create a ‘pinch point’, signalling drivers to slow upon entering the site and encourages vehicles to emerge with caution.
- The buildings have been arranged to define the edges of a space, provide continuity and create a strong sense of enclosure.
- Buildings are outward looking with windows orientated to overlook the street, providing safety and security.
- A larger building is positioned deliberately on the axis of the street to provide a focal point and ‘terminate’ or ‘close’ the view from the entrance.
- Roof heights (eaves and ridge) and roof forms, together with chimneys and dormers add visual interest to the skyline.
- Street trees provide vertical division of the space, shading, soften its appearance and increase its visual appeal.
- Hard surfacing provides horizontal sub-division of the space, visually prompts drivers to slow down and delineate areas of on-street parking.
- The ‘cranked’ building uses the built form to deflect a view into to a rear courtyard, which itself incorporates a feature focal point tree.

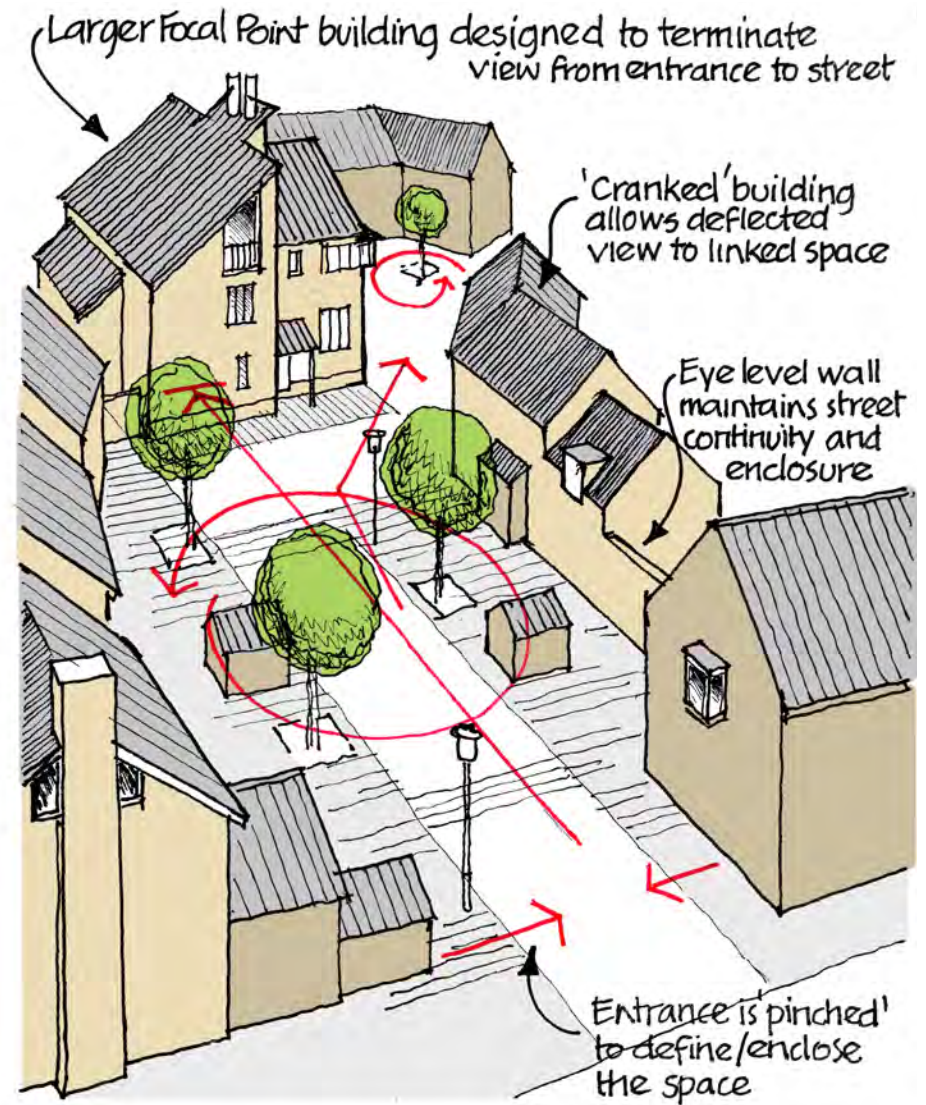

**MAKING TOWNSCAPE, MAKING PLACES for PEOPLE**

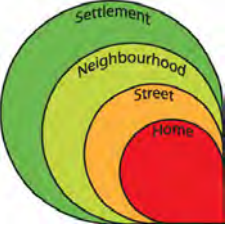

**Building for Life** criteria

**Creating a place**

**5. Character** Does the scheme create a place with a locally inspired or otherwise distinctive character?

**6. Working with the site and its context** Does the scheme take advantage of existing topography, landscape features (including water courses), wildlife habitats, existing buildings, site orientation and micro-climates?

**7. Creating well defined streets and spaces** Are buildings designed and positioned with landscaping to define and enhance streets and spaces and are buildings designed to turn street corners well?

**8. Easy to find your way around** Is the scheme designed to make it easy to find your way round?

*Most of us identify with a place... because we use it and get to know it... The only reason anyone does this much is that useful or interesting or convenient differences fairly nearby exert an attraction.*

*Almost nobody travels willingly from sameness to sameness and repetition to repetition, even if the physical effort required is trivial.*

Jane Jacobs, *The Death and Life of Great American Cities* (1994 edition)

## 3.5 Character

### 3.5.1 Character

*Developments should create places of character based upon an appreciation of the site and surrounding area, responding positively to its natural and built context.*

**3.5.2** The concept of character relates to the qualities belonging to a place that together give it its own identity and help distinguish one place from another. This is often referred to as its sense of place; so when you get 'there', you have a sense of arrival or being 'somewhere'.

**3.5.3** Character is influenced by factors such as architectural style, materials and traditions, relationship of buildings to landscape, history and economy. These factors combine to create places that are distinctive and specific to their location, not the qualities of somewhere else.

**3.5.4** New housing development is often seen as bland with little character, and unable to respond positively to its context. Many fail to create any sense of place and feel disconnected from their locality; essentially they could be 'anywhere'.

**3.5.5** Designs should 'ground' development to their location, to help foster a sense

of place, character and connection. This requires an approach that goes beyond the unthinking application of standard solutions, but instead seeks to understand and respond meaningfully to the context, site conditions, community values and needs.

**3.5.6** Locations with a weak or negative character can provide few contextual clues or positive features to build on. In these instances designers should draw inspiration from positive aspects of the wider context to design proposals that are appropriate to the locality, rather than recreate an existing poor design.

**3.5.7** In some circumstances the design of a proposal may depart from the local context and character (although it should not be ignored). For example a highly energy efficient design may have particular requirements. Such proposals must be explained and justified and will be assessed on their individual merits.



Characterless standard designs laid out without considering townscape fail to create a positive sense of place



A mature tree provides a strong focal point to this scheme and is a major element of its character

**Successful places:**

- Integrate into their setting by responding to topography, landscape planting and edges.
- Create areas of positive character by responding to prevailing characteristics in terms of: street patterns, density, layout, built form, materials and details.
- Relate the height, massing and scale of development to that nearby to create an appropriate relationship with adjoining areas. (However, variety within the built form will be encouraged in respect of townscape/place hierarchy considerations - see 3.12).
- Support local distinctiveness through the use of locally relevant materials, architectural details and building traditions, such as boundary walls etc.

**Good Practice**

Local distinctiveness:

The features that contribute to a place being rooted in its setting. These include:

- Geological setting – relationship between materials, location and building function
- Landscape character and patterns of land husbandry
- Topography and its influence on the townscape
- Land use patterns associated with local needs, traditions and industries
- Architectural forms, traditions related to local sources of materials and craftsmanship
- Place names connected with local historic associations, land ownership, topography and trades

Barton *et al.*, *Shaping Neighbourhoods*, 2010

Concerning places that lack character...

“...when you get there, there's no there there.”

Gertrude Stein, American writer

**3.5.8 Local distinctiveness**

*Developments should support local distinctiveness by taking the opportunities available to integrate the proposal into the site, its setting and the way it relates to the local area*

**3.5.9** Local distinctiveness relates to places, their qualities and peoples attachments to them. It is both physical and cultural and can seem intangible yet we are able to recognise its appeal when we see it. However, the interest and richness of places is diluted with standardisation and the associated loss of the integrity and detail that people value.

**3.5.10** Local distinctiveness has many layers, but it is about more than just variety. There is no single formula to define it, as by its nature it must be determined according to each place (hence the need to assess each site and its context). However, the organisation Common Ground has identified four indicators of distinctiveness which allow reinterpretation in each particular place. These are:



A new home with distinctive locally relevant materials

**Detail** – Detail in everyday things is important. People respond to subtle signs that add layers of richness and meaning to a place. The folds in a local field, a window or door detail, a local building tradition stimulate our senses and develop meaning.

**Authenticity** – The real and the genuine hold a strength of meaning for people, whereas the inauthentic appears one dimensional and unsatisfying. Local distinctiveness is not necessarily about beauty but it must be about integrity.

**Particularity** – The special or rare aspects of a place may be important, but it is the qualities of the common place that define its identity. The focus should be on appropriateness to and expressiveness of the time and place, rather than simply being pre-occupied by difference.

**Patina** – Age has to be recognised as having been gathered. With care, the remnants of the accumulation of activity, the layers or fragments of a place which can be read or experienced can be added to, without resorting to their loss, damage or crude interventions.

Common Ground (*Losing Your Place*, 1993)

**3.5.11** When developers engage with the community about their proposals they should use this opportunity to explore local cultural attachments and what people value about their place.



A modern design incorporates a plinth of local stone and retains existing mature trees to provide a positive setting

**Successful places:**

- Complement their context by making use of the landscape and topography of the site and the surrounding area to inform the approach to the layout of a scheme.
- Preserve and incorporate natural landscape features (such as mature trees, hedges, watercourses, ponds, rock outcrops, areas of ecological value etc) of interest or amenity value.
- Retain, reuse and enhance buildings, structures or features of historic, archaeological or local interest. Where appropriate the settings of such elements should be maintained.
- Utilise locally relevant materials associated with the landscape character area in which the site is located.
- Retain and utilise architectural features from existing buildings, structures or features if these are unable to be retained for structural or viability reasons (this must be justified).
- Recognise and retain important views.

**Sustainable?**

Does the development foster a sense of place, or could it be anywhere?

Can new themes be added or particular existing attributes strengthened?

Support local identity and sustainability by making full use of the resources to hand: reduce, reuse and recycle.

Adapted from Urban Design Compendium 1 & 2 (2007)

*In many towns... there is scope for strengthening existing neighbourhoods... or devising new areas of special character. Such 'character areas' can reinforce local identity and serve as a marketing tool to raise the profile of a particular place.*

Urban Design Compendium 1 (2007)

**3.5.12.Character Areas**

*Where appropriate to the scale of development, proposals should be sub-divided into areas of character the design of which is based upon clearly defined characteristics*

**3.5.13** In larger scale developments character areas may be devised to differentiate between different parts of the site, assist legibility and avoid large areas of repetitive housing.

**3.5.14** Proposals should assess whether the site relates to an existing area of particular character and determine how the scheme can introduce areas that strengthen character and reinforce local distinctiveness. This may influence the mix of uses, density and pattern of development, views to existing landmarks, the network of routes and open spaces, urban form, materials or other factors.

**3.5.15** There may be opportunities to introduce new elements or character areas, particularly if a place has a weak, unremarkable character. However, the context (immediate or wider) should normally provide the starting point to developing the principles that will define a character area, with the aim of strengthening the distinctiveness of the settlement and being appropriate to the place.

**3.5.16** Character areas should not be artificial creations or based upon alien designs or features from elsewhere, otherwise they will appear 'forced' and inauthentic. Instead they should be a genuine response to the place, its characteristics, constraints and the distinctive qualities of the area. This will provide integrity and reinforce local identity.

**3.5.17** The basis of each character area should be informed by a street and place hierarchy (see sections 3.6 and 3.12) and each area should have a genuine role to play in the creation of a movement net-



work and the character of the place. The street hierarchy itself should be informed by the context and what is appropriate in any given setting. This can be determined through the site context appraisal process (see Part 2).

**Successful Places:**

- Respond to the landform and natural features of the site
- Are sensitive to the characteristics of the local area, including building forms, details, layouts, edges, boundary treatments
- Vary or grade densities (influenced by factors such as location within the site, land uses and access to transport etc)
- Are influenced by prevailing land uses (existing and proposed)
- Incorporate local materials, details and building methods
- Are appropriate in scale, height and massing with regard to adjoining buildings and general heights in the area, views and local landmarks and topography and visual impact
- Provide a positive relationship with the edges of the site including any areas of open countryside

**Left:** Three distinct streets within the same development demonstrate that areas of differing character can be formed without resorting to large areas of monoculture housing



**3.5.18** Establishing the place and street hierarchy will begin to inform the characteristics of each character area.

**3.5.19** Using more than one developer or employing more than one architect to design different aspects of a scheme will also support the creation of character areas.



Bespoke railings inspired by historic details



Public art has the ability to enhance the character of a place and connect with its past

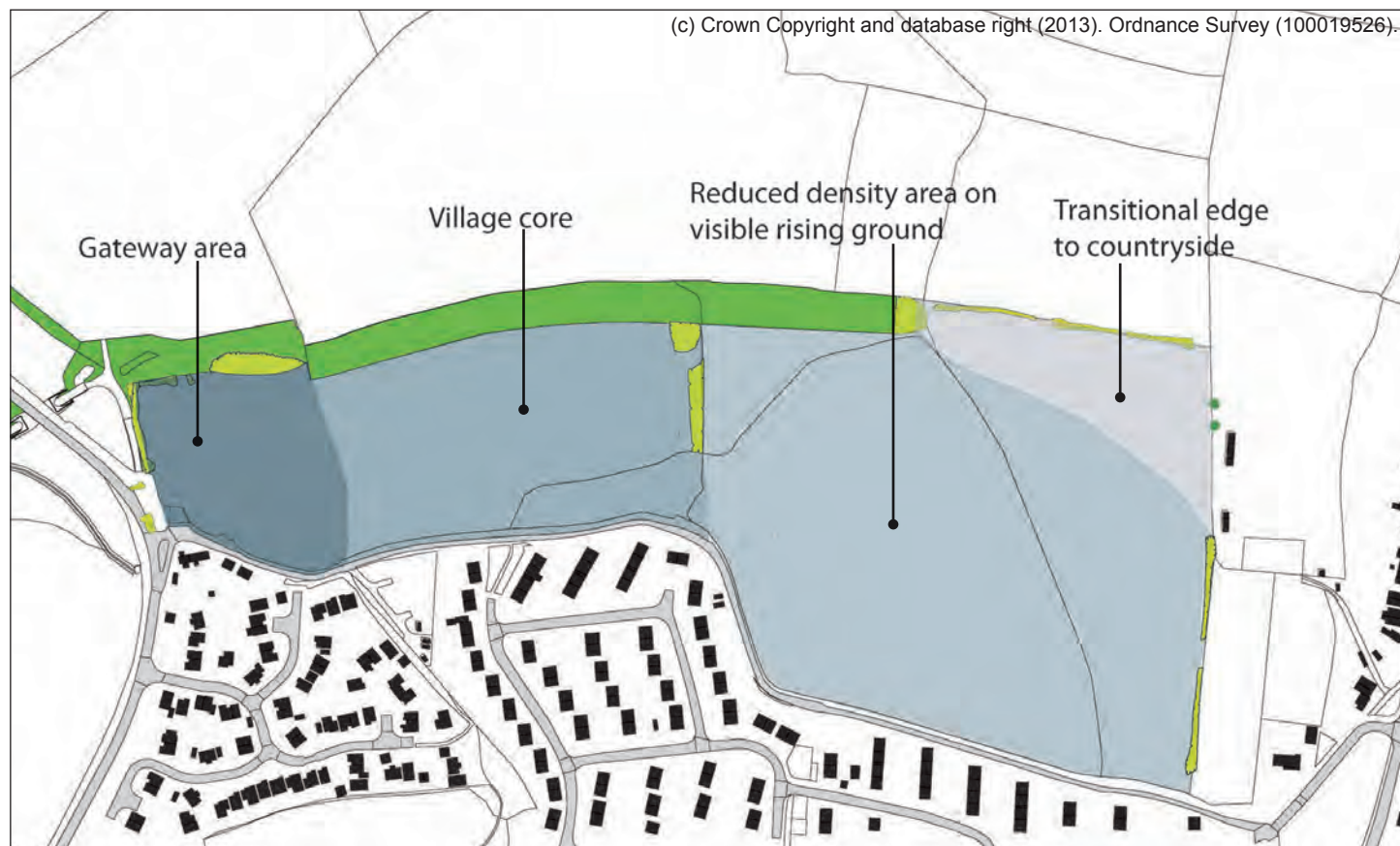

(c) Crown Copyright and database right (2013). Ordnance Survey (100019526).

**Above:** A large development site subdivided into a number of 'character areas'. The defining qualities of each area will vary to create a number of places within the scheme which exhibit their own distinct characteristics.

**Parameters to define character areas should include:**

- Street type and width;
- Building use/house types and street continuity (density/intensity of development);
- Building set-backs;
- Building height and enclosure;
- Front boundary treatments;
- Topography and landscape;
- Materials and architectural attributes.



Building for Life criteria

Integrating into the neighbourhood

1. Connections Does the scheme integrate into its surroundings by reinforcing existing connections and creating new ones; whilst also respecting existing buildings and land uses along the boundaries of the development site?

2. Facilities and services Does the development provide (or is it close to) community facilities, such as shops, schools, workplaces, parks, play areas, pubs or cafes?

3. Public transport Does the scheme have good access to public transport to help reduce car dependency?

Creating a place

8. Easy to find your way around Is the scheme designed to make it easy to find your way round?

Street & Home

9 Streets for all

Are streets designed in a way that encourage low vehicle speeds and allow them to function as social spaces?

## 3.6 Layout

### 3.6.1 Layout

*Layouts should provide a linked network of routes and spaces within the development and connect to adjoining areas*

3.6.2 The layout provides the basic plan around which the development is structured.

3.6.3 The pattern of routes, densities, uses, development blocks and individual plots influence the character and dynamics of a place. How it connects to its surroundings can also influence wider movement patterns.

3.6.4 Layouts based upon an interconnected network of streets and spaces encourage walking and cycling as realistic alternatives to the motor car and distribute vehicle flows more evenly, helping to disperse traffic.

**Successful Places:**

- Comprise internally connected layouts of routes and spaces.
- Create good access to adjoining areas, with links to existing streets and paths.
- Arrange layouts in a way that support the viability of local facilities.
- Carefully relate different uses, avoiding bad neighbour uses close to homes.

Good Practice



Where proposals are situated near to commercial activities and possible bad neighbour uses, it is advisable to seek advice from the Environmental Health Department at an early stage to identify potential nuisance issues and whether these should or can be mitigated in order to facilitate a scheme.

### 3.6.5 Variable Density

*A development, depending on its scale and context, should provide variable densities to support areas of character, the viability of local services, facilities and the landscape setting of the area*

3.6.6 Density is an important aspect of character and designing sustainable places. The layout, density and pattern of the built environment is called its 'grain'. In general terms, the central parts of settlements have a more compact, fine 'grain' with higher densities around key locations, public spaces or where the mix and intensity of land uses is high. These often provide the main focus of a place or follow important arterial corridors.

3.6.7 Densities tend to decrease with distance from the centre, becoming less dense with a looser knit urban grain towards the settlement edges.

3.6.8 Rather than applying a uniform density, densities should be varied across the site area, where the scale of development allows and having regard to its particular circumstances and context.

3.6.9 Where appropriate, densities should be graded so that higher-density development supports the viability of facilities (local shops/high streets etc) and services (such as bus stops/ public transport corridors/stations) where there is good pedestrian accessibility. This can also reduce reliance on private vehicles and the number of short trips taken by car.

3.6.10 Densities should normally be reduced towards areas of lesser activity with lower-densities along green corridors, towards settlement edges and against the countryside to assist with a graduated transition between town and country.

**Successful Places:**

- Avoid uniform densities across the development.
- Arrange the layout and density of the development in a way that supports the viability of existing or proposed local shops, amenities and public transport by providing good connections to facilities that encourage walking and cycling and reduce the number of journeys and distance travelled by car.
- Incorporate areas of differing density according to the location and character area of the site.



**Above:** Density and urban grain will vary according to the location of the site within the settlement and the type of settlement, whether town or village. Generally this will decrease with distance from the centre of the settlement.

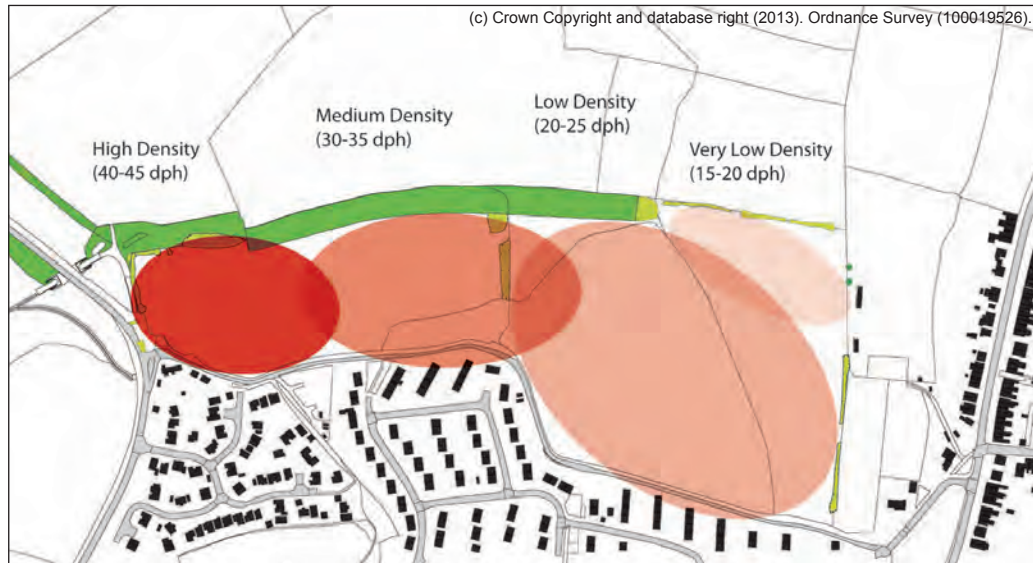

**Left:** Varying the density across a site in response to topography and in support of the creation of areas of distinct character, while achieving an acceptable overall average density across the site.

**Good Practice**

When setting out street layouts and designing corridor sections, the following aspects of movement and visual hierarchy need to be considered:

**Movement Hierarchy:**

- Traffic volume;
- No. of dwellings served;
- Type of vehicle accommodated;
- Whether or not there is direct access to individual properties;

**Visual Hierarchy:**

- Scale (the distance between building fronts);
- Enclosure (as determined by building heights);
- Carriageway and foot-path widths;
- Street trees which can subdivide a street into different zones.

Urban Design Compendium 2 (2007)

**Good Practice**

Wherever possible developers are encouraged to develop according to the Principles of Secure by Design.

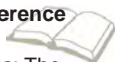
**Useful Reference**

Safer Places: The Planning System and Crime Prevention, ODPM & Home Office (2004)

**3.6.11 Street Hierarchy**

*Developments should provide a hierarchy of street types that contributes to the creation of a sense of place and facilitate movement, rather than a hierarchy that is determined primarily by traffic capacity*

**3.6.12** The relationship between streets and the adjacent buildings strongly influences the safety, appearance and movement function of a development. The layout should accommodate traffic and allow for access by service vehicles, but it should also contribute positively to the character of the development.

**3.6.13** Residential streets should not be seen simply as a conduit for traffic, but as places in their own right. Designs where parking and highway space are dominant should be avoided.

**Successful places:**

- Comprise a hierarchy of different street types that are appropriate to the place.
- Comprise streets where the character of the street and its movement function are given equal consideration (i.e. traffic needs are not assumed to take precedence).
- Ensure a considered relationship between the streets, spaces and adjacent buildings that provide their setting.



Street sections show a hierarchy of street types (Drawings courtesy of the Borough Council of Wellingborough and Matrix Partnership Ltd)

**3.6.14 Crime Prevention**

*Layouts should be designed to help reduce opportunities for crime and anti-social behaviour*

**3.6.15** The design of the development layout can help to deter anti-social behaviour and reduce opportunities for crime. Ensuring clear distinction between public and private spaces, good overlooking from adjoining buildings, lighting and avoiding the creation of potential problem areas can all minimise the likelihood for future problems.

**Successful places:**

- Design and orientate buildings to overlook streets/spaces and provide active edges.
- Ensure any pedestrian and cycle paths are short in length, sufficient width to feel safe and comfortable, overlooked and lit.
- Routes should be direct and follow desire lines to places where people want to go.
- Normally avoid rear lanes and direct access to the rear of properties.
- On-plot and off-plot parking areas should be overlooked by adjacent buildings, with an association between the building and the parking spaces wherever possible.
- Use boundary treatments to distinguish clearly between public and private space.
- Avoid potential problem areas such as awkward or poorly located public space.

### 3.6.16 Passive Solar Design

*Developments should be orientated to benefit from passive solar energy*

**3.6.17** Homes that benefit from passive solar gain use less energy for lighting and heating and generally provide a brighter and more pleasant living environment.

**3.6.18** Where practicable, the design and layout of developments should seek to take advantage of passive solar energy. Orientating dwellings within 30 degrees of south is sufficient for them to benefit from year round solar gain.

**3.6.19** However, developments should avoid layouts that are designed entirely around achieving passive solar gain at the expense of other urban design considerations. Proposals comprising of largely south facing parallel streets will be unlikely to satisfy other important design requirements.

**3.6.20** Larger south facing windows will absorb heat into the building while small north facing windows will help minimise heat loss. Shading may be required to prevent overheating in the summer. However, obstructions to south facing elevations should be limited in order to maximise the benefits from solar gain during the winter. Deciduous trees can be valuable by providing summer shade while allowing through low-winter sunlight.

**3.6.21** Care is required to avoid overheating and building designs need to consider the occupants comfort. Homes with a high thermal mass (constructed from dense materials that can absorb heat) absorb solar energy and then slowly release it at night resulting in low temperature fluctuations within a dwelling. Buildings constructed from materials with a low thermal mass are susceptible to rapid extremes of heating and cooling, creating uncomfortable living conditions.

### DESIGNING FOR SUNLIGHT

Notional spacing for 2 storey terrace housing at this latitude to allow sunlight to houses for approx 3 hours over 12 months = 25m rear to rear.  
21m spacing allows approx min 3 hours over 11 months.

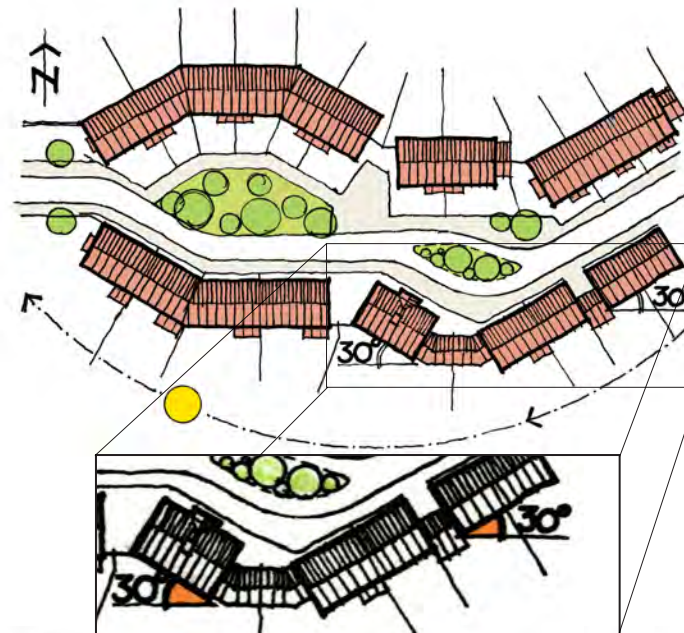
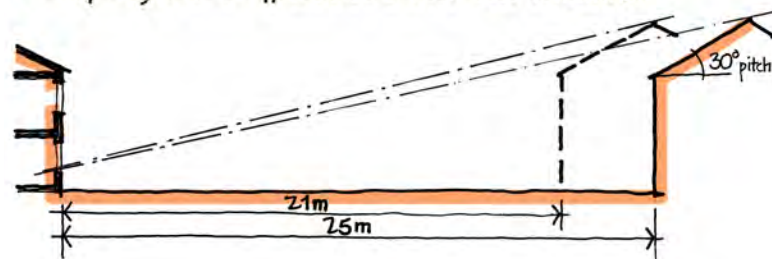

Houses with main elevations facing within 30° of south allow for optimal solar gain, whilst being sufficiently flexible to permit good placemaking, streetscapes & response to contours.

#### Successful Places:

- Orientate dwellings within 30 degrees of south, where practicable.
- Seek to provide habitable rooms with a south facing aspect.
- Design to prevent summer overheating.
- Minimise obstructions to winter solar gain.



A large window for solar gain and a deep overhang and canopy for shade



Solar panels reduce energy demand and lower running costs but need to face close to south and lie at 45° for maximum efficiency

### 3.6.22 Settlement Edges

*Developments that form a new long term settlement edge should create a positive relationship with the adjoining countryside, providing an appropriate transition between the built up area and the adjoining landscape*

**3.6.23** Development on the outskirts of towns and villages will have the effect of creating a new edge to the settlement. New edges require careful treatment to mitigate any visual intrusion and integrate schemes successfully into their setting.

**3.6.24** A development's relationship with the adjoining landscape is critical to achieving an appropriate transition between town/village and country and should be an integral consideration of the design layout.

**3.6.25** A combination of careful building design, orientation and provision of effective landscaped areas will normally be required. This does not mean simply hiding the development with screen planting (although landscape buffer planting may sometimes be appropriate). It is about creating new edges that have a positive interface with the countryside. Depending on the scale of the development, a range of measures to ease the transition between urban and rural may be required.

**3.6.26** Grading the density of development by reducing its scale and intensity towards its edges with the countryside, allows for planting within and between plots to create a featheredge to the settlement.

**3.6.27** Wherever possible, layouts should be arranged so dwellings are orientated to be outward facing to address the countryside, rather than turning their back.

**3.6.28** Where plot boundaries are located against the countryside they should normally comprise soft planting and reinforce the transitional qualities of the edge. Hard boundaries comprising only walls or fences will normally be inappropriate unless they are designed to reflect the rural character. They may also need to be combined with planting.

**3.6.29** Developments may require substantial landscape buffer areas. These should normally be outside any residential curtilage/ownership with suitable long-term management arrangements put in place to ensure their future retention. Where existing trees and hedges are present these should be retained and reinforced by new planting, if necessary.

**3.6.30** The extent of a landscape buffer area should be proportionate to the scale and impact of the development and may vary according to the prominence and sensitivity of the settlement edge, but may need to be substantial (e.g. 10 - 20m or greater) and should comprise suitable native species that reflect the landscape character area in which the scheme is located.

#### Successful places:

- Have regard to views towards the site from outside and mitigate any adverse visual impacts.
- Grade the scale and density of development to reduce towards the edges of the settlement.
- Orientate dwellings to be outward facing and address the countryside.
- Ensure the nature of any boundary treatment is appropriate to its rural character, avoiding abrupt walls or fences.
- Retain existing trees and hedges and incorporate new landscape planting within and on the edges of the development, utilising native species.
- Incorporate landscape buffer areas that are proportionate to the scale of the development and prominence or sensitivity of the settlement edge.
- Carefully consider the design of lighting schemes on settlement edges to minimise light pollution on local amenity and dark landscapes.

#### Good Practice



- Recognise and work with existing boundaries wherever possible
- Ensure most dwellings face outward and relate to the rural context
- Create a composed built edge considered alongside woodland and tree planting in manner that respects its landscape context
- Avoid hard edges, unsightly rear fences and house backs onto the open countryside
- Avoid/limit use of unbroken landscape screens as they do not allow built areas to relate to their rural setting

**Below left:** Houses set back and orientated to face towards the countryside. Their built form and siting create an interesting roofscape and a hedge and trees define the new settlement edge and assist in providing a soft transition to the countryside.



**Below right:** Houses turning their back on the countryside create a negative relationship with the adjoining landscape and standard suburban style boundary fences form an abrupt and inappropriate new edge to the settlement.



**Above:** Outward facing houses positively address the adjoining spaces and have been considered as a group to create an interesting composition and roofscape

**Above:** Standard houses and layout result in a mundane roofscape and poorly maintained fencing creates an incongruous and abrupt edge treatment

**Building for Life** criteria**Integrating into the neighbourhood**

**1. Connections** Does the scheme integrate into its surroundings by reinforcing existing connections and creating new ones; whilst also respecting existing buildings and land uses along the boundaries of the development site?

**2. Facilities and services** Does the development provide (or is it close to) community facilities, such as shops, schools, workplaces, parks, play areas, pubs or cafes?

**Creating a place**

**7. Creating well defined streets and spaces** Are buildings designed and positioned with landscaping to define and enhance streets and spaces and are buildings designed to turn street corners well?

**8. Easy to find your way around**

Is the scheme designed to make it easy to find your way round?

**Street & Home**

**9 Streets for all** Are streets designed in a way that encourage low vehicle speeds and allow them to function as social spaces?

**11 Public and private spaces** Will public and private spaces be clearly defined and designed to be attractive, well managed and safe?

## 3.7 Block Structure

### 3.7.1 Block Structure

*Layouts should be arranged in a pattern of perimeter blocks forming permeable streets with well defined frontages*

**3.7.2** The block structure is the pattern of development blocks contained within the overall layout.

**3.7.3** Perimeter blocks form connected layouts that create a walkable neighbourhood structure. This allows easy access throughout the area. Many places will already comprise a network of streets and blocks and these may be used to inform the approach to the design of the proposed block layout.

**3.7.4** The design of blocks should not necessarily be uniform on all sides. The character of each side of the block should reflect the character of the adjoining street. Variation can also be achieved by making use of building types, appropriate mixed uses and designs that respond to corner locations.

**Successful places:**

- Comprise layouts consisting of blocks that form a permeable street pattern.
- Design the pattern and shape of perimeter blocks to complement the site context and the character of the proposed adjoining streets.
- Include variation within each side of the block (density, height, scale, use) to reflect the hierarchy and status of surrounding streets (main frontages, side streets, lane/mews) and contribute to the character, identity and function of each street frontage.
- Arrange development to be outward facing to overlook streets and public places with the primary access to buildings from the street via a clearly identifiable front entrances.
- Address key corners with special corner buildings or groups that address both sides of the corner with active frontages.

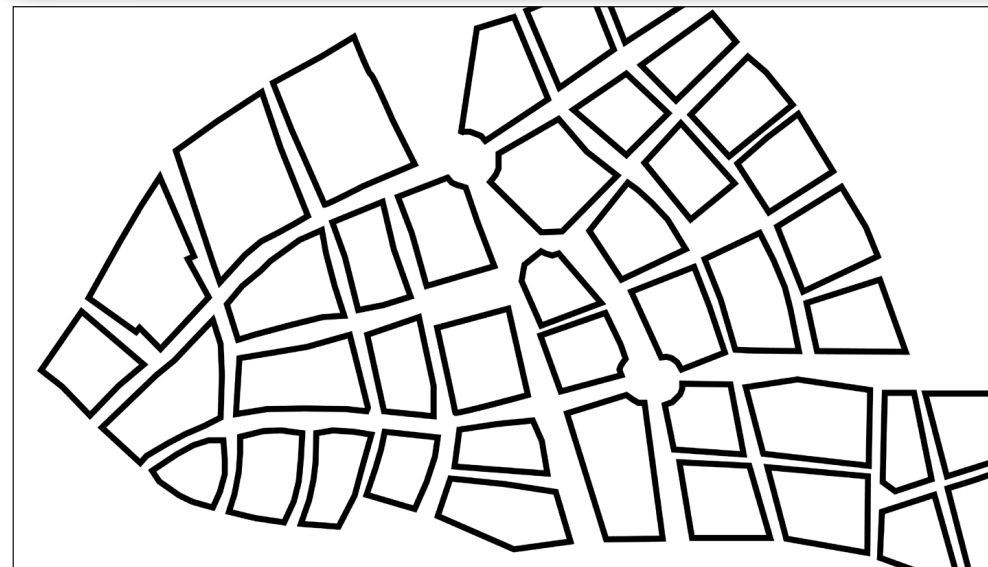

**Above:** A connected layout of development blocks that creates a walkable development



## THE URBAN BLOCK

- Effective method of site/plot utilisation
- Differentiates clearly the public & private sides
- Creates coherent street layout
- Enables safer homes

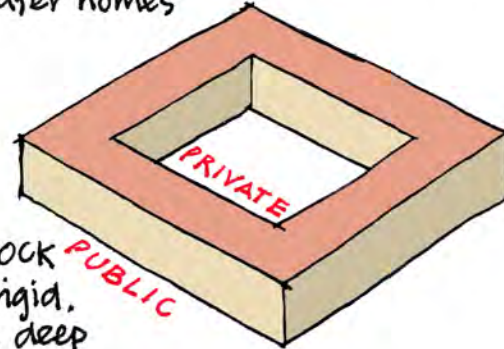

**FORMAL BLOCK**  
 Can be too rigid,  
 Can create deep  
 shadowing on  
 private side

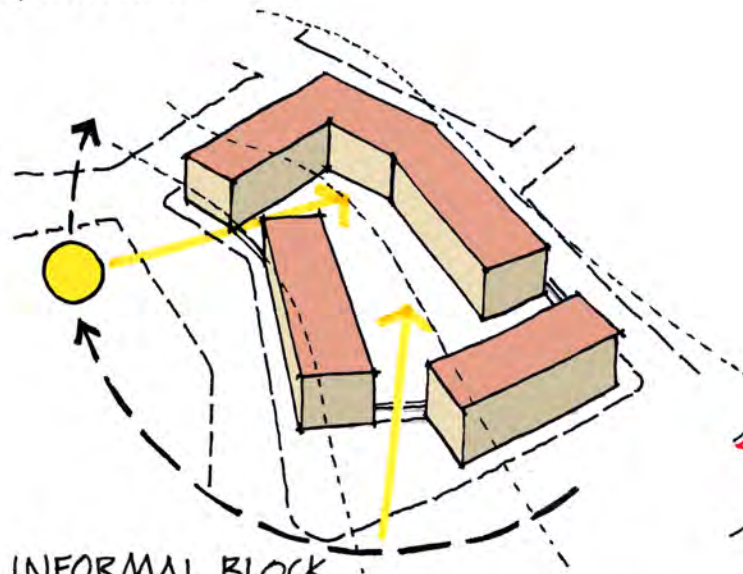

**INFORMAL BLOCK**

- Allows sun penetration / reduces shadowing
- Improved air quality & outlook
- Follows contours & other site factors
- Creates interesting street/space layout



low density block



medium density block



'urban' mixed use block

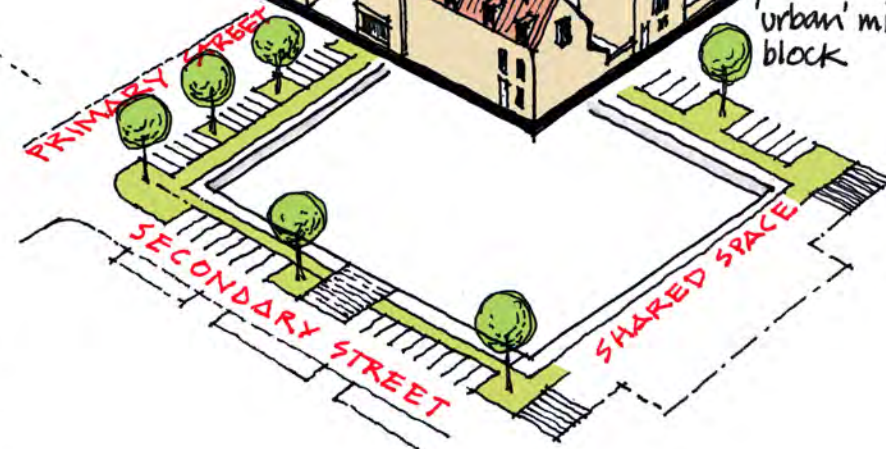

### 3.7.5 Block size and shape

*The size and shape of blocks should form part of a permeable street pattern and respond to the conditions of the site*

**3.7.6** Perimeter blocks can be designed in numerous ways and may be formal or irregular. Key considerations when determining the size and shape of the block are:

- The permeability of the area (over-large blocks can reduce permeability);
- Density;
- Parking strategy;
- Privacy and amenity;
- Daylight and natural ventilation;
- Topography;
- Potential uses of the block interior (if not private gardens);

**3.7.7** Irregular block shapes can offer greater flexibility and be designed to:

- Respond to the specific conditions of the site (e.g. existing features or topography);
- Assist in slowing traffic;
- Optimise orientation for good light penetration;
- Create focal points and interest in the street scene;

**3.7.8** Block sizes can vary widely, but blocks of 60-90m x 90-120m provide the optimum dimensions to support good pedestrian accessibility, vehicle movement and allow for sufficient back to back/back to side separation distances.

**3.7.9** Larger blocks provide scope for incorporating an interior court that can accommodate a variety of uses, such as play, parking, communal gardens or off-street service areas. Alternatively they may be sub-divided by mews streets for access, to accommodate parking and improve permeability. Blocks with open interiors should be overlooked with managed access wherever possible.

#### Successful Places:

- Ensure block sizes and arrangements are varied with frequent spacing (informed by the context).
- Ensure block shape responds to the site conditions, topography and the character of the surrounding area.
- Incorporate secure interior spaces (including private gardens).

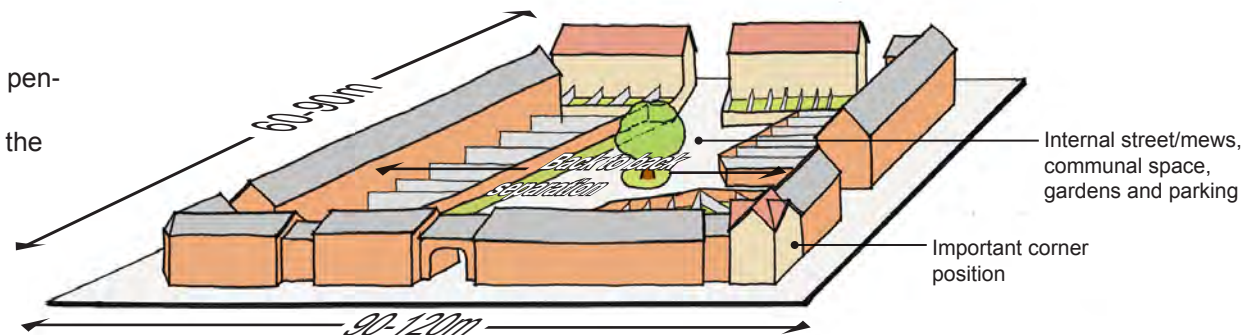
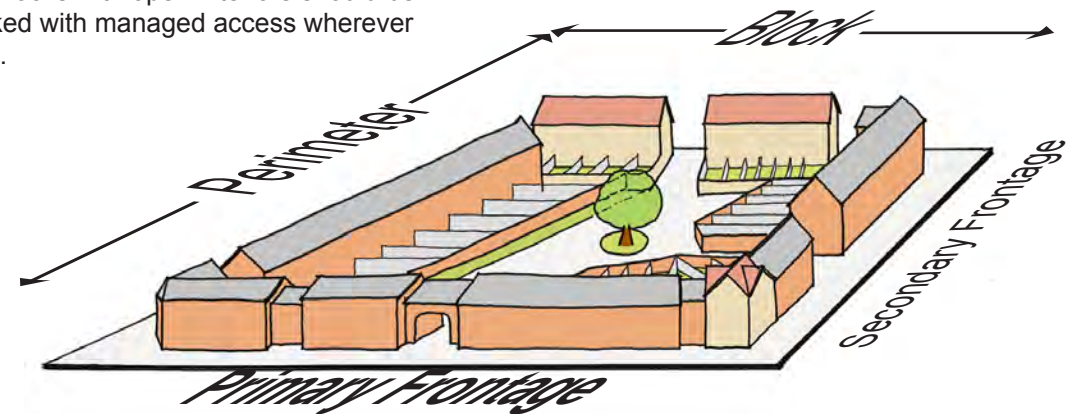

#### Useful References

Urban Design Compendium 1 (2007)

Shaping Neighbourhoods, Barton *et al*, (2010)

### 3.7.10 Culs-de-sac

*The provision of culs-de-sac should normally be avoided unless particular site conditions dictate that a cul-de-sac design is the most appropriate way to develop the site. In such circumstances this should be explained and justified*

**3.7.11** Layouts designed around a distributor road and cul-de-sac model have a number of disadvantages. However, in some circumstances, the provision of cul-de-sac designs may be necessary as a means of developing a difficult site or where particular constraints impose limitations that prevent connections being made.

#### What are the disadvantages of culs-de-sac?

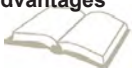

- They can be difficult to navigate - everywhere looks the same and they don't take you directly to where you want to go.
- They can create awkward 'left over' or poorly defined spaces.
- They result in lots of blank frontages often creating characterless and unappealing pedestrian environments.
- They also favour cars over pedestrians and other users, making it awkward to reach facilities or public transport.

Adapted from Manual for Streets DCLG, DoT, WAG (2007)

#### Successful places:

- Avoid overlong culs-de-sac and ensure any through connections for pedestrians and cyclists are overlooked with active frontages to make them feel safe.
- Avoid concentrating large volumes of traffic on a small number of dwellings.
- Design turning heads to form part of a space not just for turning manoeuvres.
- Ensure adequate parking is provided so turning areas remain clear of parked cars.
- Arrange the layout to avoid rear boundaries backing onto public street frontages.

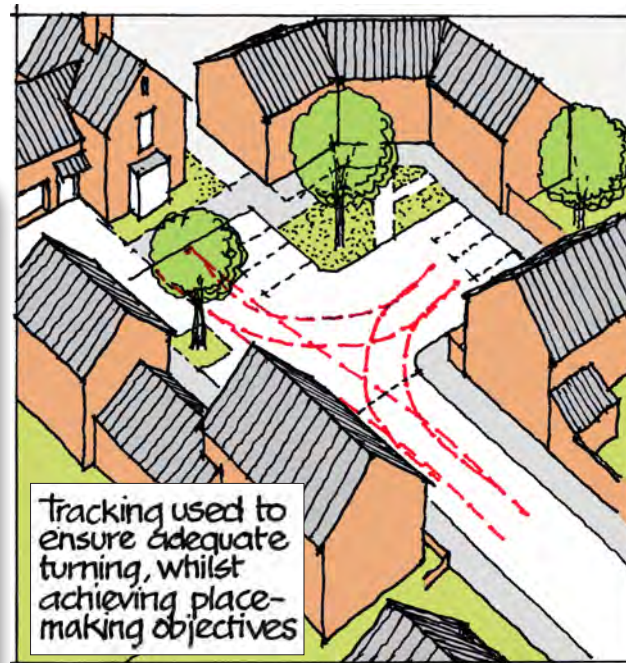
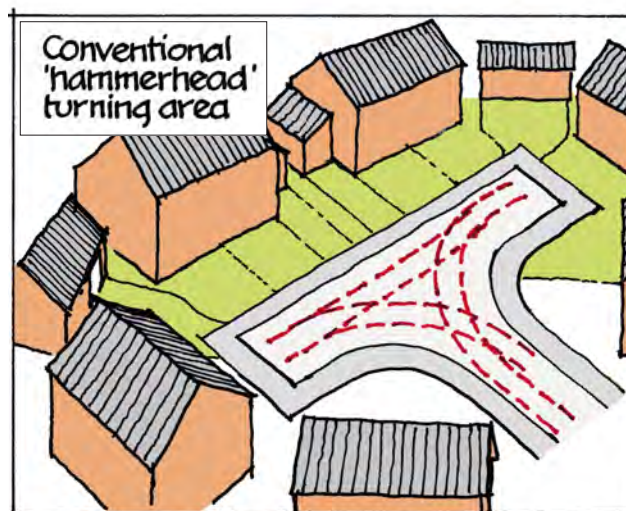

Culs-de-sac are designed primarily around the needs of the car and lack a sense of place



A cul-de-sac backing onto street with fencing maintained in various states appears scruffy



Houses turning their back onto the adjoining street creates a poor dead frontage

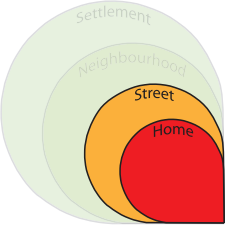

**Building for Life** criteria

**Street & Home**

**9 Streets for all** Are streets designed in a way that encourage low vehicle speeds and allow them to function as social spaces?

**10 Car parking** Is resident and visitor parking sufficient and well integrated so that it does not dominate the street?

**12 External storage and amenity space** Is there adequate external storage space for bins and recycling as well as vehicles and cycles?

## 3.8 Parking

### 3.8.1 Approach to parking

*Parking provision should provide a balanced mix of parking solutions that are integrated into the design and layout to support its appearance without cars becoming visually dominant*

**3.8.2** Sustainable public transport can provide an alternative to or complement car use. However, car ownership is an established aspect of modern life and satisfactorily accommodating parked cars is a key function of most residential streets.

**Successful places:**

- Provide a mix of parking options appropriate to site location and context.
- Integrate parking into the design/layout without detracting from the character or appearance of the place.
- Provide parking environments that are attractive, convenient and safe.
- Generate activity/movement between dwellings and the street creating safe, animated places.
- Provide surveillance of parking areas from adjoining buildings and gardens.

**3.8.3** Designs need to reconcile the need to provide attractive streets that include adequate parking, but without detracting from the character or visual quality of the place. Well designed places integrate car parking without it becoming over-dominant.

**Below:** A housing layout incorporating a well designed mix of parking solutions, including on-plot provision, rear parking courts and on-street spaces designed into the street scene (Drawing courtesy of Davidsons Group Ltd).



Parking occupying whole frontages dominates the street scene and detracts from its appearance.



Rear parking court



On-street provision



On-plot parking

“ Plan for car ownership while planning for less car use. ”

Urban Design Compendium 2, English Partnerships & Housing Corporation, 2007

**Sustainable?**

The level of parking should be determined in conjunction with accessibility of the site to public transport and its level of service.

Suggested standards for public transport frequency are:

**Excellent:** 5 mins or higher. At this level of frequency travellers are able to change bus to bus with little time penalty.

**Good:** 6-12 mins. Travellers are able to wait for buses on spec – casual use possible

**Regular:** 13–30 mins. Dependable. Timetabling essential. Wait time is not long.

**Mediocre:** 40–120 mins. Journeys have to be carefully planned.

**Poor:** over 2 hours. Residual level of service. Awkward to use.

**Rural bus services:**  
**60 mins. - Adequate**  
Stops within 10 minutes walk of homes.

Adapted from Sustainable Settlements, Barton, *et al*, (2010)

Car Parking: What Works Where  
English Partnerships (2006)

Guidance Note Residential Parking, Institute of Highway Engineers (2012)

**3.8.4 Levels of Parking**

*The level of parking provision should be determined by the site context, its sustainability and accessibility to public transport, employment and other local amenities*

**3.8.5** The level of parking provided will be partly determined by the location of the site and its sustainability in terms of its proximity to local services and public transport. Well connected sustainable locations with good access to shops, services and employment opportunities may be able to reduce levels of parking. However, other important influences on car ownership are dwelling size, type and tenure and these should be a factor in deciding the appropriate level of parking.

**3.8.6** Over-provision of parking wastes land and is likely to discourage the use of more sustainable modes of transport. Conversely, under-provision can detract from the quality of the place, causing indiscriminate parking or the conversion of front gardens to provide additional spaces, with a resulting loss of front boundaries, plot definition and enclosure of the street, as well as increased surface water run-off.

**3.8.7** The level of parking and density of development can impact on the quality of the environment. Where schemes propose high levels of parking relative to

the density of the development, this can be difficult to accommodate without it appearing too dominant or intrusive.

**3.8.8** Banks of unrelieved parking, with a lack of front boundary treatments/open frontages, poorly considered landscape, prominent integral garages or extensive areas of driveway undermine the character and appearance of schemes. This can be an indication that the density of development is too high, if this is the only way that parking is able to be provided.

**3.8.9** The level of parking must therefore be determined having regard to a range influencing of factors while always seeking to avoid the negative impacts of parking on the design and appearance of the street scene.

**Successful places:**

- Incorporate an appropriate level of parking but at the minimum level necessary to facilitate the development.
- Provide reduced levels of parking in the most sustainable locations with access to good public transport where these provide a viable alternative to the car.
- Configure the amount of parking provided with regard to the needs of dwelling size, types and intended tenure.



(Photo: Tibbalds Planning & Urban Design Ltd)

Trees and generously landscaped front gardens moderate the visual impact of frontage parking and achieve a good balance between providing an appropriate level of parking and the quality of the environment.

**Good Practice**

Typical Parking Space  
Dimensions:

*Perpendicular parking:*

Bays:

- w 2.4m x l 4.8m

*Required reverse distance:*

- at 90° = 6.0m

- at 60° = 4.2m

- at 45° = 3.6m

*Parallel parking bay to the street:*

- w 2.0m x l 6.0m

Source: Manual for Streets,  
DCLG, DoT, WAG 2007

**3.8.10 On-Street Parking**

*On-street parking should be designed as an integral component of the street scene and support the character and role of the street*

**3.8.11** On-street parking can contribute to the character and vitality of a place, bringing movement and people onto the street. It is also a flexible way of providing parking that can adapt to changing levels of car ownership, cater for peak demands from different users and can also serve to slow vehicles and buffer pedestrians from traffic.

**3.8.12** On-street parking must be balanced with road safety and crime prevention considerations. Road widths and levels of parking also need to be sufficient to avoid inappropriate parking on pavements and appearing visually dominant in the street scene.

**3.8.13** Any on-street parking should be designed as an integral component of the street scene that supports the character and role of the street, within the place hierarchy and parking strategy.

**Successful places:**

- Provide on-street parking as part of a mix of parking options.
- Incorporate attractive streets that allow for unallocated on-street parking.
- Avoid large banks of uninterrupted or visually intrusive parking.
- Delineate on-street parking spaces through use of surface treatments.
- Moderate visual impacts with small groups of spaces separated by trees or features that provide opportunities to cross safely.
- Generally provide for visitor parking through unallocated parking spaces.
- Limit visitor spaces in accessible locations.



On-street parking integrated into the streetscene with hard and soft landscape (Tibbalds Planning & Urban Design Ltd)



Informal on-street parking provided by subtle widening of the carriageway



Cars obstructing pavements due to inadequate road space and parking provision



Frontage parking accommodated within an attractive space

*Allocating spaces makes car parking less efficient as the spaces may be left unused even when there is demand for them.*

Urban Design Compendium  
2, English Partnerships &  
Housing Corporation, 2007



**Above:** Parallel and perpendicular on-street parking arranged in small groups, differentiated through surface materials and broken up with street tree planting



**Below:** On-street parking within an informal courtyard setting with street trees that soften the appearance of the parking and enhance the quality of the space

“  
 Indicating on-street parking spaces clearly through the use of road markings or changes in surfacing material can help to encourage good parking behaviour.”

Manual for Streets, DCLG, DoT, WAG, 2007



On-street parking designed into the street scene and identified by changes in surface material



The impact of on-street parking is reduced by careful street tree planting (Photo: Andy Cameron)



On-street parking arranged perpendicular to the carriageway

### 3.8.14 Garaging and on-plot parking

*On-plot parking and garages should be sited so they do not appear as dominant features in the street scene and be sufficient size to function as a parking space*

**3.8.15** Drives and garages should normally be located to the side/rear of houses to minimise their visual impact. Any parking in front of a dwelling should maintain the maximum extent of front boundary possible in order to provide a clearly defined edge to the private space and enclosure to the street.

**3.8.16** Garages are flexible spaces that can provide secure parking, although they are also often used for domestic storage or sometimes converted to additional living accommodation. This is a reflection of the generally low internal space standards of many new dwellings.

**3.8.17** For a garage to count as a space towards parking provision it must meet minimum internal dimensions to satisfactorily accommodate a car (see Table 1). This includes provision of space for household storage, such as bicycles, prams/push chairs or waste/ recycling bins, tools/work bench etc.

**3.8.18** Garages are unlikely to be used if they are too small and impractical to easily park and exit from a car. This essentially reduces the provision of useable parking space and displaces it onto the road. This affects the quality of the place and may cause problems with highway safety or obstruct access by service vehicles.

**3.8.19** The size, design and siting of garaging can also impact on the character and appearance of the street scene. Proposals should avoid visually intrusive garages that detract from the appearance of the development or result in dead frontages.

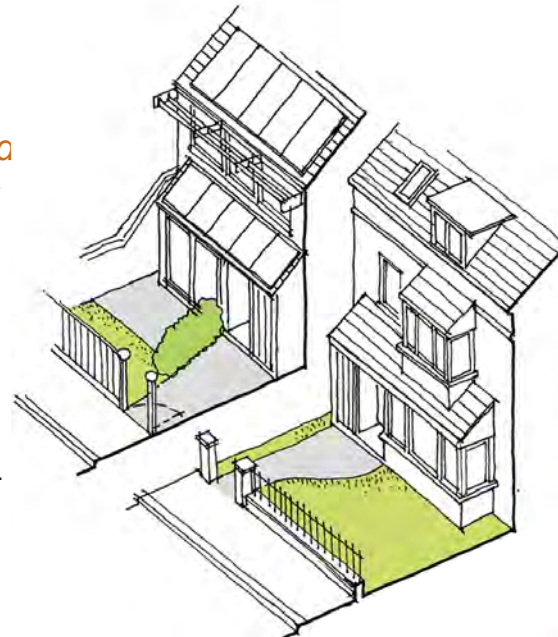

Above: A driveway between houses tucks cars away.

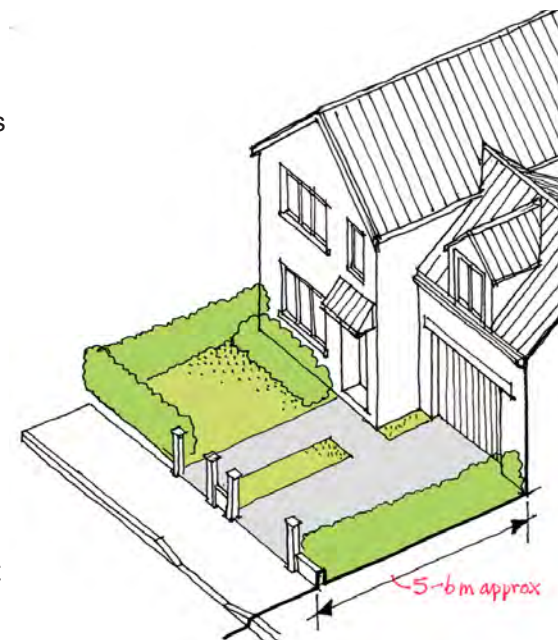

Above: Frontage parking minimises the drive while front boundaries maximise enclosure and definition of the plot.

#### Successful places:

- Ensure houses with on-plot parking maximise the extent of a well defined vertical front boundary.
- Locate parking between houses to avoid visual impacts on the street scene.
- Avoid uninterrupted banks of frontage parking and mitigate the impact of any parking in front of houses with well designed landscape.
- Normally avoid garages that project beyond the building line/visually intrude into the street scene.
- Design garaging with enough space to accommodate a car and allow the driver to exit comfortably.
- Avoid an over-reliance on integral garage house types to minimise car/garage dominated frontages.
- Where integral garage house types are used, garaging should not dominate the main elevation.
- Setback parking to be clear of the footway.



Parking discretely positioned between houses





Garages designed to meet only minimum dimensions are so small that they are often impractical for parking a car. Consequently they are not used for their intended purpose, increasing on-street parking.

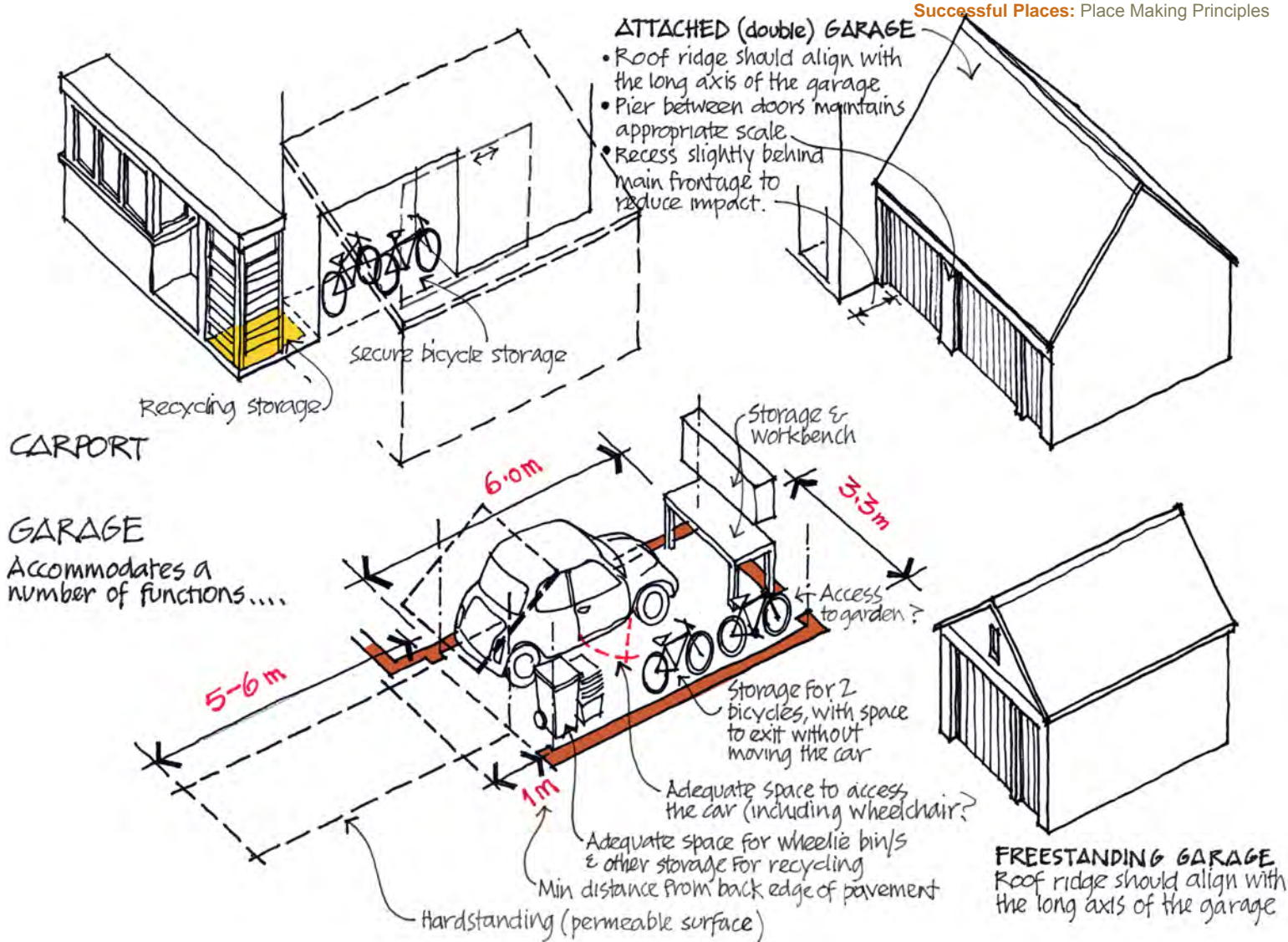

Integral garages and frontage parking dominate the appearance of these houses

**Table 1:** Minimum internal garage dimensions necessary to count as a parking space

Garage Type	Internal Dimension (m)	Min Door Width (m)	Counts as Parking Space Y/N
Single	6 x 3	2.3	N
Single (inc. storage space)	6 x 3.3	2.3	Y
Double (inc. storage space)	6 x 6.3	4.2	Y
Double	6 x 6	4.2	N
Disabled	6 x 3.3	2.8	Y

Source: adapted from 6Cs Highway Design Guide (2010)

**Table 2:** Minimum garage setback

Garage Door Type	Min set-back (m)
Roller shutter/sliding/inward opening	5
Up and over	5.6
Hinged outward opening	6

Source: 6Cs Highway Design Guide (2010)

### 3.8.20 Parking Courts

*Parking courts should be safe, convenient and attractive spaces in their own right so they form an integrated part of the residential environment*

**3.8.21** Parking courts provide off-street parking located internally within a development block, which can help reduce the visual impact of vehicles parked on the street. However, parking courts have often been neglected areas in the design process, being seen as functional backland areas rather than an integral part of the residential environment. The result is often a bleak, utilitarian and unappealing space.

**3.8.22** If parking courts are too remote, inconvenient or unpleasant they can exacerbate on-street parking problems as owners choose to their park cars closer to their homes. Where used, they should be small in size and ideally include one or more properties within the court (sentry units) to give a sense of ownership and security. Multi-accesses should normally be avoided and routes between parking spaces and their associated dwellings should be short, direct and convenient. Sufficient lighting is also required so that users feel safe after dark.

**3.8.23** Large rear parking courts have a reduced sense of ownership, are less private and can feel unsafe, offering opportunities for crime and anti-social behaviour. Poorly designed courts will discourage their use, displacing parking onto surrounding roads. This can cause streets to become crowded with cars and result in inconsiderate parking habits. The location, design and quality of parking courts should aim to encourage their use by residents to minimise the likelihood of such problems occurring.

**3.8.24** Where parking courts are provided, this should normally be as part of a suite of parking arrangements across the development, rather than the sole means of providing parking.

#### Successful places:

- Normally avoid large parking courts greater than 10-12 spaces.
- Break up the layout of larger parking courts and include some residential units (sentry units) to provide natural surveillance and contribute to their character interest.
- Create attractive spaces using surface materials and tree and shrub planting to form courtyards not car parks.
- Ensure robust, attractive boundary treatments.
- Carefully incorporate areas of planting without unduly restricting illumination or natural surveillance of the parking court.
- Feel safe and secure, include lighting and natural surveillance, ideally allowing the keeper of the vehicle to see their own car.
- Provide safe, convenient and direct routes to the properties they serve with as short a walking distance as possible.
- Provide supervision of the parking court from adjoining gardens via boundary treatments that allow inter-visibility for casual surveillance.



An attractive parking court enhanced by trees and overlooking from adjacent houses



Soft planting and a restrained palette of hard surface materials successfully break up a larger parking court

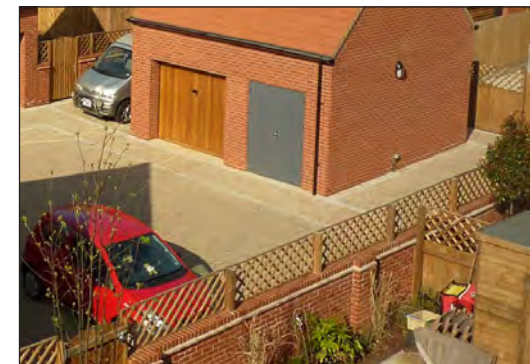

Interior courtyard parking with a robust boundary treatment, topped with trellis allowing intervisibility from adjacent gardens

**Right:** A parking court is more than just a car park. It should be both attractive and safe to encourage its use,

### COURTYARD PARKING

Gable end windows help surveillance of entrance to courtyard

Parking areas are overlooked by multiple windows  
Trellis topping 1.5m walls aid visibility

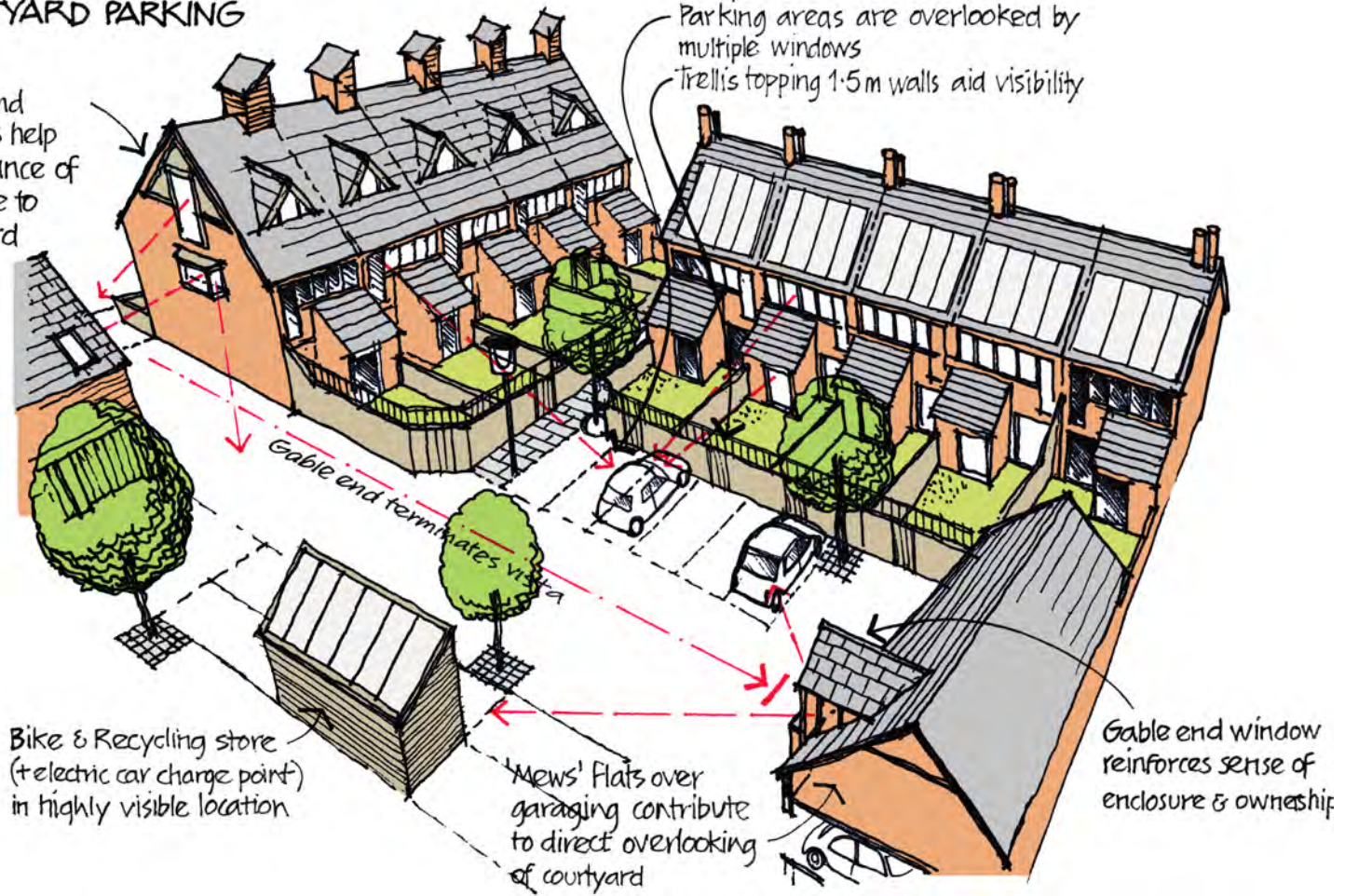

**Below:** Natural surveillance, attractive surface materials, the inclusion of soft planting and robust boundary treatments are key elements of well designed parking court.



**Below:** Robust boundary walls topped with trellis to aid surveillance of parking areas from adjacent gardens



**Right:** Often parking courts are poorly designed spaces with limited appeal. Here timber fences provide a weak means of enclosure, overlooking is poor and the absence of hard and soft landscape combine to create an unappealing space.





## Building for Life criteria

### Creating a place

**7. Creating well defined streets and spaces** Are buildings designed and positioned with landscaping to define and enhance streets and spaces and are buildings designed to turn street corners well?

### Street & Home

**9 Streets for all** Are streets designed in a way that encourage low vehicle speeds and allow them to function as social spaces?

**10 Car parking** Is resident and visitor parking sufficient and well integrated so that it does not dominate the street?

*“The place function is essentially what distinguishes a street from a road...”*

Manual for Streets, DCLG, DoT & WAG, 2007

### Useful References



6C's Highway Design Guide  
www.leics.gov.uk/htd

Manual for Streets, DCLG, DoT & WAG, 2007

Manual for Streets 2, CIHT, 2010

Streets for All: East Midlands,  
(Parts 1 & 2), English Heritage  
www.helm.org.uk

## 3.9 Street Design

### 3.9.1 Streets not roads

*Roads should be safe, inclusive and an integrated component of the design in a way that helps create streets and places not just roads for carrying traffic*

**3.9.2** In order to achieve high quality, innovative and attractive residential places the Highway Authorities of Derbyshire and Nottinghamshire County Councils are committed to working closely and flexibly with Local Planning Authorities, developers and other stakeholders in the process.

**3.9.3** Whilst it clearly remains important to consider safety within the design, the overall philosophy has evolved from providing highways for the movement of vehicular traffic to the creation of streets and places that allow for movement by all modes but which are also established seamlessly, in their own right, within the urban fabric.

**3.9.4** It should be appreciated that a more flexible approach also places greater responsibility on the Design Team to demonstrate that the proposals will operate safely and satisfactorily, are maintainable and sustainable, and to justify the design choices that have been made.

**3.9.5** Full design guidance is contained within the 6C's Design Guide document. It is not necessary or desirable to replicate substantial parts of that guide within this SPD and the information below therefore provides an indication of the main technical design issues to be considered and addressed. It is stressed that the content of 6C's DG should not be interpreted as promoting specific standards or as prescriptive. It is accepted that unnecessary rules and restrictions can inhibit innovation and, as a consequence, can prevent schemes from reflecting local character and distinctiveness. The guidance should therefore be used flexibly within the context of place in a holistic design process.

**3.9.6 Junction & access visibility splays** It is expected that the design speed of streets within residential places will not normally exceed 20 mph and that speed restraint will be achieved through the design and layout of the streets and the locations of buildings and features, and not by using physical traffic-calming features.

**3.9.7** Generally, for a 20 mph design speed, visibility should be available from a point 2.4m back from the carriageway edge of the priority route, representing the distance between the front of a vehicle and the driver's position. From this point visibility of 25m (27m for bus routes) should be provided measured along the nearside carriageway edge.

**3.9.8** Where the visibility splay is at a street junction it will generally need to be constructed in a manner such that it is eligible for adoption as highway maintainable at public expense. At private accesses the splays must be capable of being kept free of solid structures or dense planting, and an appropriate condition of planning permission may reflect this.

**3.9.9** The Highway Authority will consider changes to visibility provision, if it can be demonstrated that vehicle speeds will be restricted as a result of the design and layout of a scheme.

**3.9.10** Intervisibility between driver and pedestrian should also be maintained at private accesses by the avoidance of solid structures and dense planting immediately adjacent to the access, at the rear of the footway. However, boundary treatments can be important elements of character and in defining street edges. A balance therefore needs to be achieved that maximises enclosure/definition, while satisfying any intervisibility requirements.

**3.9.11 Carriageway widths** Generally, where there is separate footway provision adjacent to a carriageway, the carriageway should be minimum 4.8m wide for access to up to 50 dwellings and minimum 5.5m wide for up to 400 dwellings. Carriageway widening will be required on bus routes and where it is intended to

accommodate on-street parking. However, within any scheme it is expected that carriageway widths should also reflect the role and function of the street within the overall street and place hierarchy, having regard to the context and the character of development being created.

**3.9.12** A surface shared by all users, appropriate for up to around 50 dwellings, should normally be 8.8m wide. Additional widening may be required to accommodate any proposed on-street parking. Where sections of narrower shared surface carriageway are proposed these will need to be discussed with the Highway Authority. Corridors may reduce to 7.5m where there is development on one side of the road (comprising elements of service strip, carriageway and margin).

**3.9.13** Care is required to avoid single-surface areas that appear out of scale with the domestic buildings flanking them. Changes of material or material unit size that are appropriate to the use of the space (defining vehicle routes, thresholds to drives/parking courts, entrances to buildings, defining key pedestrian crossing routes etc) should be used, so that the landscape design responds appropriately to the scale of the space, to ensure it is proportionate and functions appropriately.

#### 3.9.14 Vehicle tracking

Vehicle tracking assessments will be required as necessary, in order to demonstrate the traffic can be satisfactorily accommodated without, for example, having to mount kerbs and footways. This should take account of any planned or likely on-street parking.

#### 3.9.15 Footway widths

Footways should be minimum 2.0m wide but subject to widening as necessary to reflect function within a particular place or context. In some circumstances it may be possible to provide a full width footway on only one side of the street, for example where the street would serve only a small number of dwellings or is a particularly narrow site. Conservation areas or rural settings may dictate a more informal approach to the design. Although it is likely that the footway would be necessary on both sides of the junction radii to aid pedestrian crossing.



**Above:** Vehicle tracking demonstrating access and turning within the site is capable by a large refuse collection vehicle (Drawing courtesy of Caunton Properties Ltd, highway consultants Stirling Maynard and JWA Architects).

#### 3.9.16 Junction radii

Radii should not normally be greater than 6m in order to restrict vehicle entry and exit speeds and to avoid excessive crossing distances for pedestrians. Reduced radii may also be accepted subject to consideration of the design context and to the submission of tracking diagrams that demonstrate the route of vehicles relative to the proposed layout.



**Building for Life** criteria

Creating a place

5. Character

Does the scheme create a place with a locally inspired or otherwise distinctive character?

6. Working with the site and its context

Does the scheme take advantage of existing topography, landscape features (including water courses), wildlife habitats, existing buildings, site orientation and micro-climates?

7. Creating well defined streets and spaces

Are buildings designed and positioned with landscaping to define and enhance streets and spaces and are buildings designed to turn street corners well?

Street & Home

9 Streets for all

Are streets designed in a way that encourage low vehicle speeds and allow them to function as social spaces?

10 Car parking

Is resident and visitor parking sufficient and well integrated so that it does not dominate the street?

11 Public and private spaces

Will public and private spaces be clearly defined and designed to be attractive, well managed and safe?

## 3.10 Public Realm Design

### 3.10.1 Creating robust, quality places

*Areas of public realm should be both robust and attractive*

**3.10.2** High quality public realm adds significant value to all forms of development. In residential schemes, this value is reflected both economically in higher rents and property values and through enhanced quality of life, including through reductions in crime and anti-social behaviour.

**3.10.3** Appropriate development of schemes following the place making principles set out within the SPD will create high quality public realm space; attention to the detailed design of these spaces will ensure their successful delivery.

**3.10.4** There are two aspects to the detailed design of these spaces; hard landscape and planting. Poor execution of either of these design aspects can have a permanent negative effect on a scheme. Developers should consider commissioning landscape architects to undertake the design of these aspects on all but the smallest schemes.

**3.10.5** To ensure that the public realm is appropriately considered and capable of delivery, full details of the hard landscape and planting designs is preferable at the submission stage of any planning application. Where full details are not

able to be provided at this stage, visuals of proposed conceptual approach to the treatment of the public realm are strongly encouraged. Hard and soft landscape should not be designed as a separate element or an afterthought, but as an integral component of the overall design.

### 3.10.6 Hard Landscape

*Using a simple palette of complementary materials, the architecture of an area and the activities of its inhabitants should give character to the streets*

*The choice of hard materials must reflect this intrinsic street character whilst also achieving continuity of movement, flow and, with it, connectivity*

**3.10.7** The design of the public realm should not exaggerate the diverse character of places.

**3.10.8** The hard landscape comprises paving, steps, ramps, boundary features, and street furniture. A good design will bring these elements together in a coherent



Hard and soft landscape used to create an attractive residential street (Courtesy of Davidsons Group Ltd)

manner that is appropriate to the needs of the individual scheme, not an ad-hoc collection of 'standard details'.

**3.10.9** The most important function of paving is to provide a hard, dry, non-slip surface that is durable, easily maintainable and that will carry the traffic that needs to use it. Analysis of successful paving illustrates that there is rarely a change in material or surface pattern without a practical purpose. The choice of materials and design detailing must be capable of satisfying all of these functions and can be summarised into the following requirements:

- Be fit for purpose and hard wearing.
- Be simple and unifying.
- Be sustainable through lifetime costing /valuing.

### Successful places:

- **Reinforce character.** Paving brings unity to diverse places and nebulous areas that need a common background and immense variety is obtainable within a limited range of materials. Alien paving patterns or an excessive variety of materials often creates confusion.
- **Provide a sense of direction.** Examples include pedestrian routes across squares and parks, or, service vehicle routes through shared surface areas. Successful routes are direct.
- **Provide a sense of repose.** Neutral, non-directional paving has the effect of halting people. Areas of sitting, meeting, or gazing to distant views should be paved in this way.
- **Indicate a hazard by change of material or pattern.** For example, paved junctions at side streets warn drivers that they are crossing or entering a pedestrian environment. This technique must be used consistently across a scheme.
- **Reduce scale.** Introducing a change of material to affect the scale of a space requires subtlety to avoid making the paving overly important. Paving should not aggressively proclaim its presence but provide background.
- **Choose the right material for the space.** Rigid materials such as slabs and blocks work best in geometric forms where cutting can be minimised. Where the space is fluid, for example curved edges or undulating ground, flexible materials such as concrete, blacktop or small unit setts should be used.
- **Create appropriate boundaries.** Fences, railings, and walls must be selected according to their function. Ask if they are required at all? Would they be robust enough for their location? Are they the right height? Vertical elements will have an impact on the quality of space, and getting the scale wrong can have a negative effect on a scheme that seems to work on plan.
- **Reduce clutter.** Minimise street furniture to reduce clutter and long-term maintenance liabilities. Keep street lighting to the back of kerbs or on buildings and minimise the use and number of poles for signage. Use bollards to protect vulnerable areas, not to overcome the problems of a poorly designed layout – e.g. keeping cars off 'left over space'. Put seats where it would be comfortable and attractive to sit, include some benches with backs to assist the elderly.
- **Maintenance access.** Anticipate where maintenance vehicles may need to go and ensure that the paving is capable of taking the weight – e.g. access to light columns, green areas for grass cutting, and play areas.

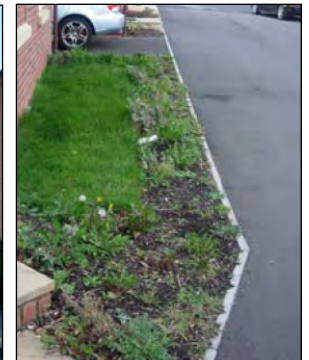

**Above:** Poorly considered public realm detracts from the quality of the environment (Photos: Top and centre right Cabe)

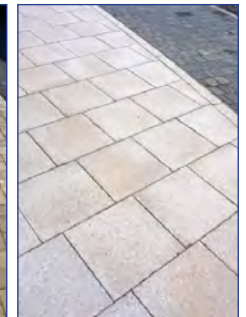

**Above:** Good quality materials make an important contribution to the character of the place

**Left:** Hard and soft landscape brought together in an attractive composition to create a 'place'

**Good Practice**

Generally avoid permanent planters, containers, or raised beds as these are comparatively expensive, incur high maintenance costs, do not always provide ideal conditions for plant growth.

**Useful Reference**

*Biodiversity by Design*  
(Town and Country Planning Association)

Advice on planting species appropriate to specific landscape areas can be obtained from:

The Landscape Character of Derbyshire, Derbyshire County Council

Landscape Character Assessment, Bassetlaw, Nottinghamshire (2009)

**3.10.10 Planting**

*Planting should create and reinforce character, scale, continuity and variety throughout the seasons.*

**3.10.11** It is not the primary role of planting to soften visually harsh environments, screen off poor design or fill left over space.

**3.10.12** Planting can promote biodiversity, help combat aspects of climate change by absorbing CO<sub>2</sub>, offers shade and reduces reflected heat from hard surfaces aiding cooling and reducing energy use.

**3.10.13** Planting is made up of trees, shrubs, grass and aquatics. They all need space to grow, both above and below ground. They also require appropriate drainage, water, nutrients, and maintenance to thrive.

**3.10.14** Planting schemes should be developed as part of the overall design public realm with emphasis on the 3rd and 4th dimensions, not just in plan form.

**3.10.15** Consider the eventual size of the planting, ensuring that there is both space for it to grow, and that its impact will not be detrimental to adjacent constructions or uses. Remember that plants are living things and that interesting layouts on plan will not be realised if their environment is hostile.

**Successful places:**

- **Reinforce character.** Planting should provide enhancement, focus, and intimacy, positively contributing to the quality of space. Planting is an integral part of the overall design and must not be used simply as a space filler or barrier.

- **Deliver quality rather than quantity.** The creation of green oases and strategically located planting must have real impact, in terms of scale, location, and nature.

- **Consider location.** Planting may be inappropriate in locations where it would obscure important features and facades or traffic sight line requirements. Position planting where it will survive its environment and flourish, considering light, water and shelter requirements and coordinate with underground services to promote successful establishment.

- **Have realistic expectations.** Whilst it is best to plant street trees directly into the ground, they should be given sufficient space to avoid their roots being cramped by buildings, street foundations, or constrained by underground cables and pipes. They face damage from vehicles and contend with air and soil pollution. Surrounding pavements also restrict air and water from reaching the roots. Trees should be planted in a suitable tree pit and growing medium to maximise their chance of survival.



Planting provides many benefits including shading windows and cars as well as enhancing the space



Trees arranged within a new square will mature to make major contribution to the character of this place



Street trees add to the quality of the environment



- **Be sustainable.** The detailing of tree pits is fundamental to success and should be as large as possible. It is preferable to plant trees in uncontained, free draining tree pits and to sustain growth, it is essential to back-fill with good quality, nutritious urban tree soil. Ideally, plant trees in groups, with the tree pit forming a continuous trench or island of soil.
- **Integrate with hard areas.** Tree grilles maintain the continuity of paving around trees, protect and aerate tree root systems and allow rainwater irrigation. Tree grilles are also an important visual element.
- **Borrow landscape.** Planting in private gardens will have a positive impact on the public realm too, and where it is difficult to plant trees in the street for example, it may be appropriate to plant them in front gardens, following the above requirements. However, a significant drawback to planting in private space is the loss of long-term control over the overall scheme – freeholders may choose to remove any planting on their property.
- **Safety and security.** Planting design should take full account of minimising opportunities for crime and anti-social behaviour when selecting locations and species for planting. Planting should support secure by design principles by providing buffer zones between public and private spaces, avoid creating areas for concealment and not unreasonably impeding natural surveillance.

“...Public space relates to all those parts of the built and natural environment where the public has free access. It encompasses: all the streets, squares, and other rights of way, whether predominantly in residential, commercial or community/civic uses; the open spaces and parks; and the public/private spaces where public access is unrestricted (at least during daylight hours). It includes the interfaces with key internal and external and private spaces to which the public normally has free access...”

ODPM Caring for Quality 2004

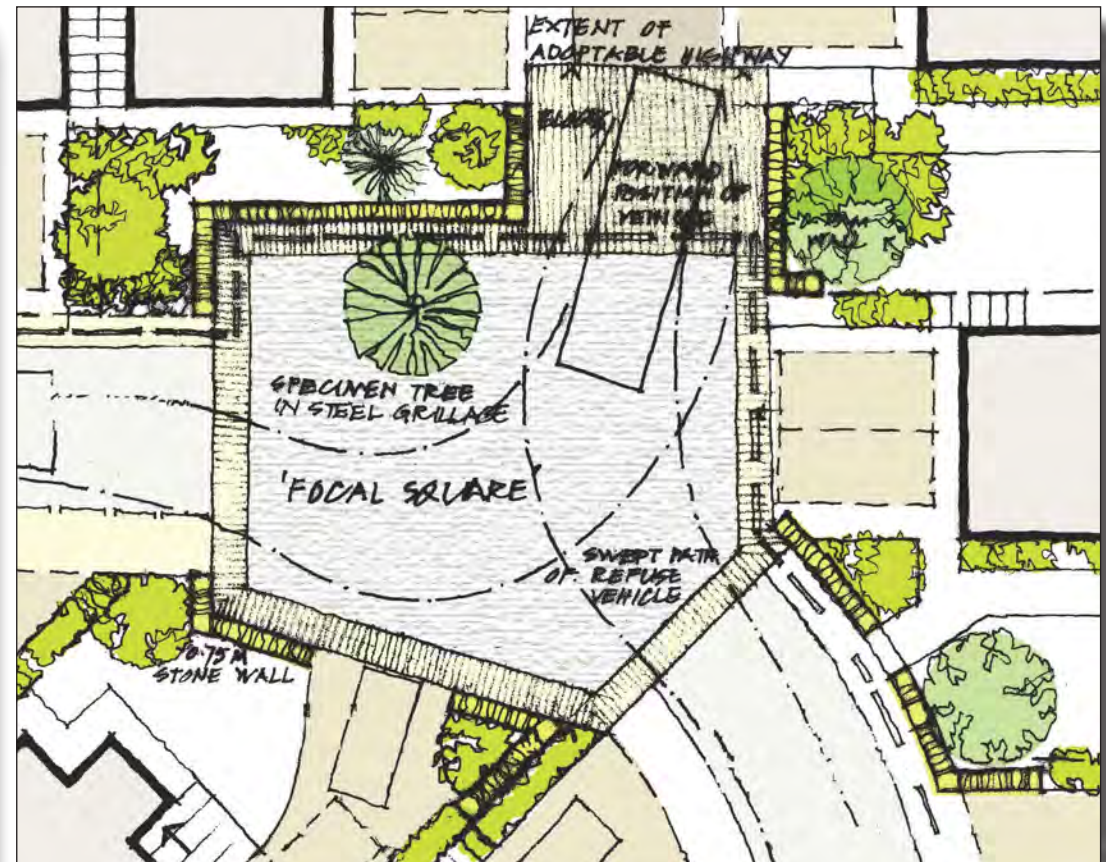

**Above:** Planting designed in conjunction with the creation of a space. A specimen tree situated within a square will form an attractive and interesting focal point for the development, without hindering access by service vehicles. (Drawing courtesy of Pinfold Securities and David Black, Architect)



Building for Life criteria

Street & Home

11 Public and private spaces

Will public and private spaces be clearly defined and designed to be attractive, well managed and safe?

12 External storage and amenity space

Is there adequate external storage space for bins and recycling as well as vehicles and cycles?

Useful Reference

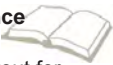

Source: Site layout for daylight and sunlight: A guide to good practice (2nd ed), BRE, 2011

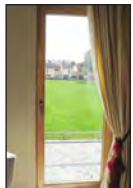

Wide windows have more potential for overlooking, whereas windows with slender vertical proportions can be used to allow only a narrow field of vision

## 3.11 Amenity

### 3.11.1 Privacy by design

*Proposals should ensure a satisfactory level of privacy with existing dwellings and between dwellings within the development itself*

3.11.2 Amenity describes the living conditions for the occupants of a home or place. Acceptable living conditions should always be provided for new and existing occupants.

3.11.3 If amenity is not properly considered in the design process, this can detract from quality of life in terms of privacy, noise, light, outlook, or overbearing development. To ensure the occupants of existing or proposed housing have an acceptable level of amenity, proposals should demonstrate how they have responded to amenity considerations.

3.11.4 Minimum separation distances have traditionally been used to ensure reasonable levels of privacy and daylight. This can be effective, but if applied too rigidly, can encourage uniformity, limit the potential to create more varied and interesting places and may restrict the redevelopment of more constrained sites.

3.11.5 However, the application of standards must be balanced against the desire to create good quality places with character and where appropriate, increased densities. Acceptable privacy can normally be achieved through careful, considered design.

3.11.6 To ensure a reasonable level of privacy the distance between facing

habitable room windows should normally be in accordance with the principles set out in Table 3 opposite.

3.11.7 The normal minimum acceptable separation distance is determined by drawing a line between the two windows (one on each dwelling) from their nearest points and measuring the angle that this direct sight line creates at each window.

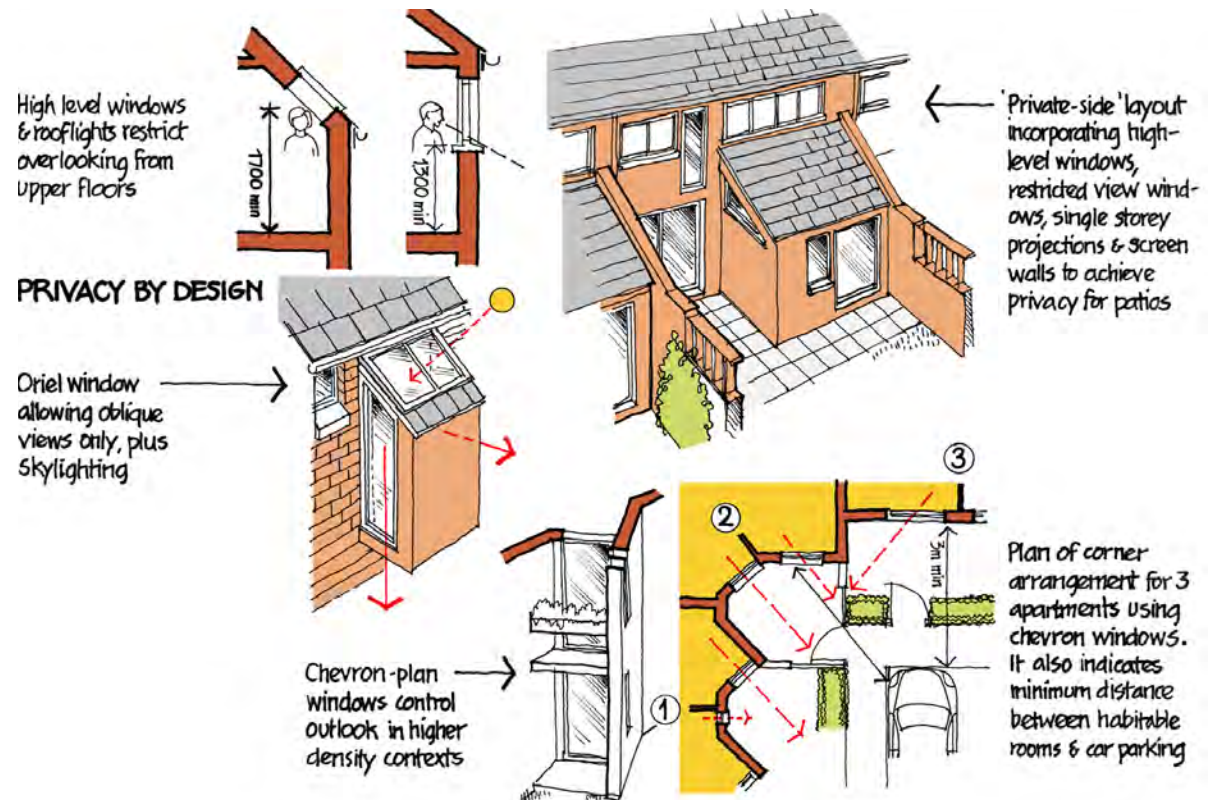

**Good practice**

**Definitions:** Privacy is considered in terms of the relationship of main windows to habitable rooms.

**Habitable rooms are:**

- Living rooms
- Dining rooms
- Kitchens
- Bedrooms
- Other rooms not defined as non-habitable rooms

**Non-habitable rooms are:**

- Hall/landing/circulation areas
- Bathroom/WC's
- Utility rooms
- Garages or other ancillary buildings or rooms

**A main window is:**

- The largest or most important window within a room.

**A secondary window is:**

- The smaller window to a room served by more than one window.

**High level windows are:**

- Windows with a cill height 1.7m above floor level.

**Obscure glazing is:**

- Glass which is permanently opaque or patterned to prevent it being transparent, such that neighbour privacy would be maintained.

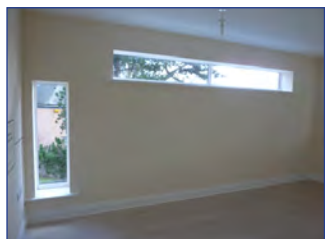

Windows designed to restrict overlooking but still allow light in

**Table 3:** The minimum distances (m) between facing habitable room windows on neighbouring dwellings that will normally be expected.

		Angle of direct sight line at dwelling A							
		90°	80°	70°	60°	50°	40°	30°	20°
Angle of direct sight line at dwelling B	90°	21	21	20	19	18	16	12	8
	80°	21	20	19	18	16	12	8	
	70°	20	19	18	16	12	8		
	60°	19	18	16	12	8			
	50°	18	16	12	8				
	40°	16	12	8					
	30°	12	8						
	20°	8							

**Below:** Examples of building angles and separation distances in accordance with the principles of Table 3 above.

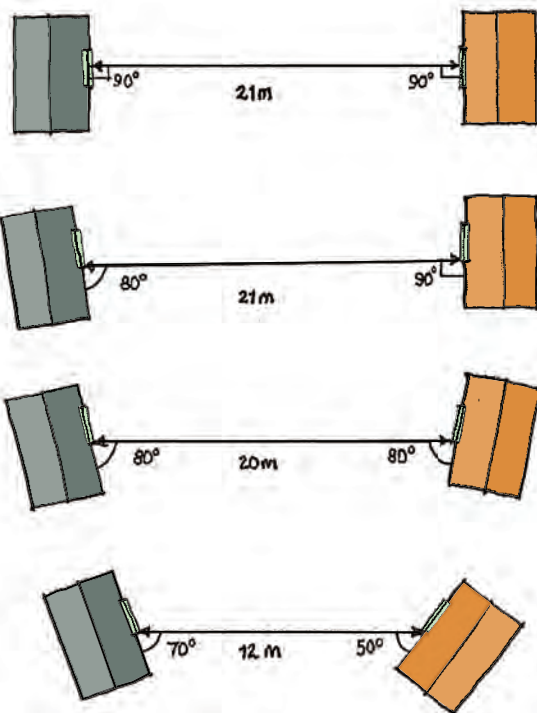
**Successful places:**

- Design the internal layout of habitable rooms with regard to their relationship to the habitable rooms of other dwellings (existing and proposed) to prevent unacceptable levels of overlooking and loss of privacy.
- Locate non-habitable rooms to limit overlooking where a habitable room would otherwise be unacceptable.
- Use the separation, placement and orientation of dwellings to one another to ensure reasonable levels of privacy between neighbouring properties.
- Use window design in terms of shape, size, height and position to allow light penetration but limit opportunities for overlooking.
- Make use of screen walls, fences, ancillary out-buildings and/or planting to moderate overlooking and maintain privacy.

**NOTE:** Minimum separation distances should be applied reasonably having regard to the particular site conditions and context. Separation distances may need to be relaxed or increased depending on the specific circumstances, such as location, the conversion of existing buildings, the character of the area, topography or other relevant considerations, for example:

- The existing pattern or character of a place has established a lesser standard where reduced distances may be acceptable;
- Sloping sites where the difference in levels would aggravate overlooking problems;
- Where direct overlooking could be prevented by appropriate screening.

**Good practice**

Separation distances:

- 21m between the rear elevations of two dwellings directly facing one another;
- 12m front to front (min); and
- 12m rear to a side wall/gable.

These are accepted 'rules of thumb' in most suburban settings and remain a useful benchmark/starting point for assessing matters of privacy. However, with careful design they may be able to be relaxed.

Sustainable?

Can dark internal spaces be lit using passive methods such as sun pipes?



These could lower running costs and reduce CO2 emissions.

**3.11.8** Where new houses are built adjoining the private garden space (usually the rear garden) of an existing dwelling, there will often be some loss of privacy to that garden.

**3.11.9** To reduce the effect of direct overlooking from new houses, first floor habitable room windows directly facing a rear boundary should not normally be sited closer than 10.5m to the boundary of an adjoining residential garden. However, not all circumstances are the same and some flexibility should be applied with regard to the extent of overlooking and the relationship between houses and gardens (similar to that outlined in Table 3 with respect to overlooking between windows).

**3.11.10** Where this cannot be achieved or where the new dwelling is judged to result in an adverse impact on amenity, it may be necessary to limit its height.

**3.11.11 Light and proximity**

*Proposals should not cause a loss of daylight, overshadowing or create overbearing relationships between buildings where this would be detrimental to residential amenity*

**3.11.12** Reasonable levels of daylight and sunlight should be provided to interiors. The amount of natural light to internal spaces should be maximised where possible to create comfortable spaces and reduce reliance on artificial lighting. Layouts should normally seek to minimise loss of direct sunlight or overshadowing of new or existing homes.

**3.11.13** The relationship between buildings in terms of their proximity should also be designed to avoid buildings that would be unduly imposing or appear overbearing to neighbouring occupiers.

**3.11.14** The site conditions, context and location will influence the significance attached to light and proximity considerations. Reduced levels of light and closer proximity between buildings may be more reasonably expected, and usually tolerated, in more urban locations or where these qualities reflect the prevailing pattern of development or would create a place with a particularly positive character, good quality townscape and allow for increased densities.



A high density scheme maintains some private garden space through carefully designed windows and siting neighbouring buildings at an angle to the garden

**Successful places:**

- Avoid relationships between buildings that result in excessive dominance or overshadowing of habitable spaces.



A naturally lit room with direct access to the rear garden

**NOTE:** In general, a range of measures can be used to assess the loss of light, degree of overshadowing and privacy levels for occupants resulting from particular proposals. The methods outlined in this guidance establish one approach that can be used by the local planning authority when considering a proposal. Other methods include those in the *Code for Sustainable Homes* (Category 7 - Health and well-being and the accompanying Technical Manual) and *Site layout for daylight and sunlight: a guide to good practice (2nd ed)*, published by the Building Research Establishment (BRE), 2011.

Exceptions to the guidance in this document may be made for creative solutions that adequately address amenity issues, where evidence can be provided to demonstrate an acceptable level of amenity will be achieved or to solve design issues associated with the particular circumstances of the site.

Southern facing slopes can be used to accommodate buildings of varying height, without overshadowing.

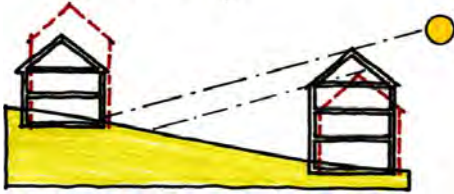

The careful location of garages & outbuildings, roof profiles & the spacing of buildings can allow sunlight to reach gardens & adjacent buildings, in higher density groups.

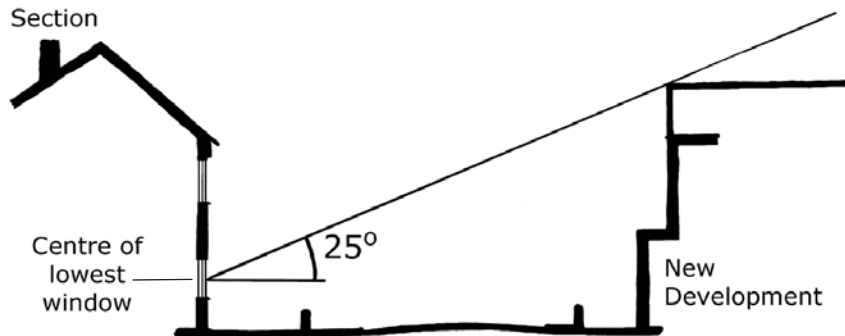

**New Build in front of a main window to a principal room: The 25° Rule**

Generally a building should not be situated in front of a main window to a habitable room if it is higher than the 25° line drawn from the centre of the affected window.

**EXTENSIONS & IMPACT ON DAYLIGHT: THE 45° RULE**

As a general rule for windows affected by a side extension, a significant reduction in daylight is likely to occur if the centre of the affected window (1) — or a point 2m above ground level for patio doors — is covered by the shaded area delineated by the 2 45° lines.

The 45° Rule should be applied flexibly, taking into account site conditions. Loss of SUNLIGHT may require additional checks.

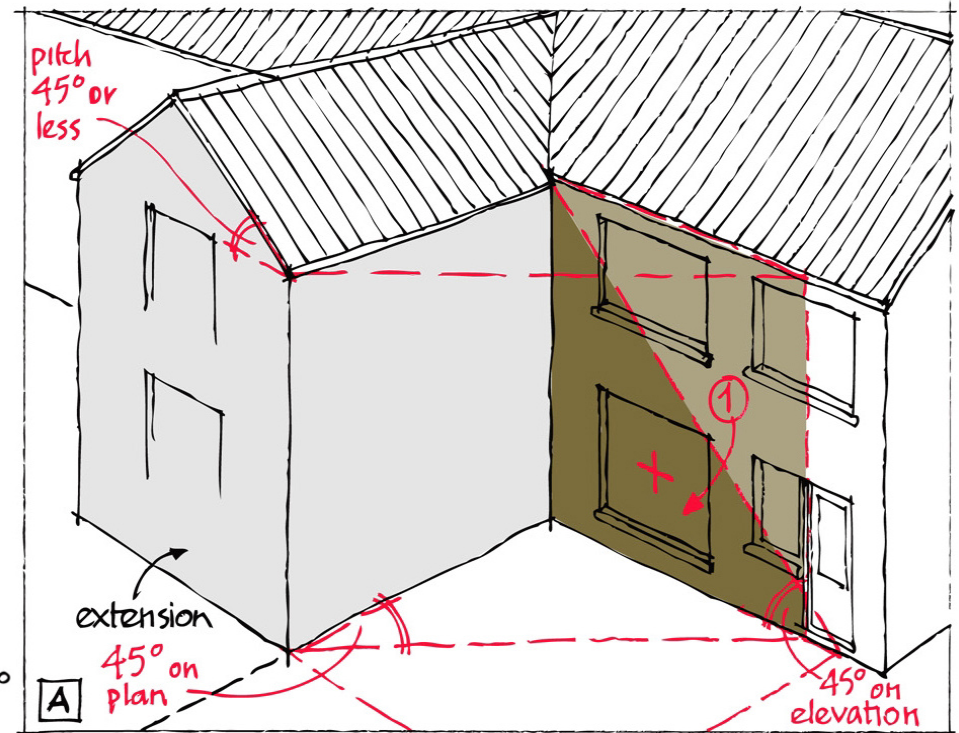

**A** 2 storey extension fails the 45° rule as both shaded areas cover window 1

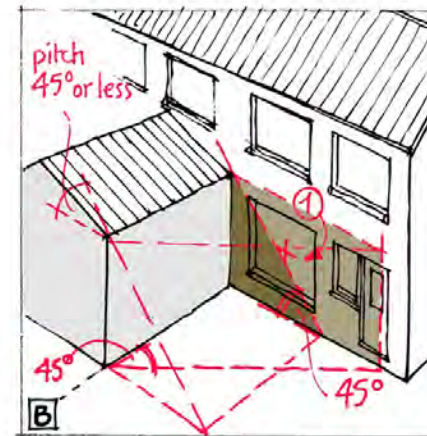

**B** Single storey pitched roof extension passes the 45° rule as mid-point of window '1' is only covered by one shaded area.

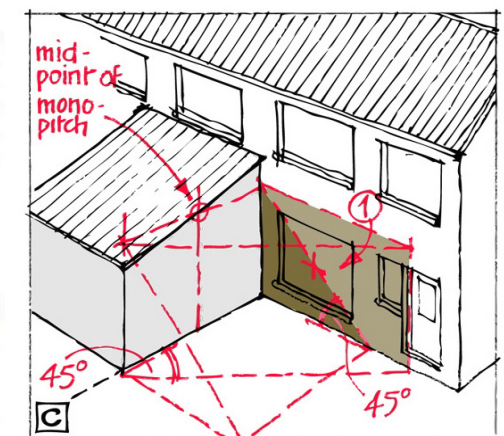

**C** Single storey monopitch extension fails the 45° rule as mid-point of window '1' is covered by both shaded areas.  
 ▶ Minor changes in projection of the extension or eaves height could reduce the loss of daylight.

**Sustainable?**



Garden sizes: **25 sqm** is only adequate for passive activity.

**60-100 sqm** is enough for sitting out and for children's play.

**160 sqm** can allow a family of four to become self sufficient in vegetables (N/B gardens would need to be larger again to also include space for children's play and sitting out).

Responsive Environments  
Bentley *et al* (2005)

**3.11.15 Private Amenity Space**

*All schemes should provide a level of outdoor amenity space that is proportionate to the type of accommodation, appropriate to its location and suitable to meet the occupiers likely requirements.*

**3.11.16** Dwellings should be provided with enough private outdoor space to meet the likely needs of the occupants. Family houses are likely to require larger gardens, preferably in the range of 70-100 sqm, but not normally less than 50 sqm.

**3.11.17** Where small gardens are necessary the aim should be to orientate them to benefit from afternoon sun or where possible to provide an alternative sitting out area, such as at the front of the property. Gardens facing northerly directions benefit from being longer to compensate for overshadowing.

**3.11.18** Wherever possible, flats should also be provided with some outdoor amenity space, whether private or communal. Ground floor flats have the potential for their own private gardens. Upper floor flats should be provided with 25 sqm of space per flat. Collectively this can provide a reasonable communal outside space.

**3.11.19** Where balconies and roof terraces are provided these areas can count towards the 25 sqm requirement for each flat. However, the overall requirements for flats may be relaxed in town centre locations, for barn conversions and

where existing buildings are converted to flats or for houses in multiple occupation.

**3.11.20** Dwellings should normally have a minimum single area of private open space, excluding parking areas and garage spaces in accordance with Table 4.

Dwelling type/No. of bedrooms	Minimum outdoor amenity space requirements (sqm)
1 or 2 bed house	50
3 bed house	70
4+ bed house	90
Flats	25 per flat
Residential institutions	20 (per resident)

**Table 4** Minimum size amenity spaces



**Above:** A decent single outside space should be the aim for all new houses

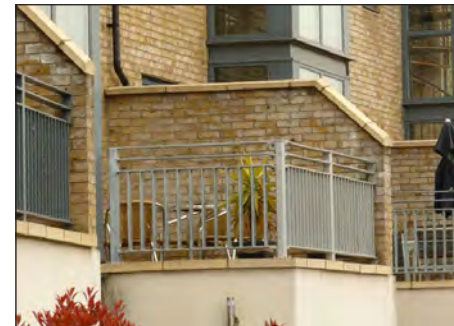

Cramped gardens are unsuitable for family accommodation

**Successful places:**

- Provide outdoor amenity space that is suited to the accommodation.
- Aim to maximise light and privacy of private garden spaces.
- Incorporate direct access to the gardens from habitable rooms.
- Find innovative ways of incorporating outdoor amenity space, particularly at higher densities and for conversion of existing buildings.

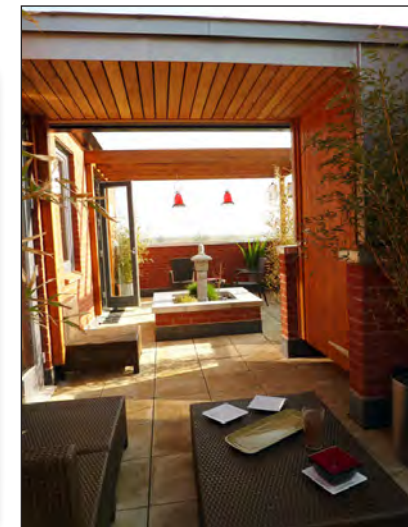

**Above and centre:** Roof terraces can offer an innovative way of incorporating outside space



**Top and above:** Communal gardens for flats provide a large usable outside space that should be appropriately managed



**Centre and right:** Balconies to individual flats provide a modest private space that allows scope for personalisation

### 3.11.21 Outlook

*Dwellings should have a reasonable outlook that does not detract from the quality of the residential environment*

**3.11.22** The quality of the environment and outlook from a dwelling influences the quality of life for its occupants. All dwellings should be provided with a reasonable outlook. Where they would look out onto unsightly spaces or buildings, poorly designed parking areas, rear walls, fences or similarly inappropriate settings, these will not normally be acceptable.

#### Successful places:

- Avoid or minimise any unsightly outlook from residential properties.



A single aspect street where houses (right) overlook rear fences (left) providing an unappealing outlook



An internal area overlooked by homes but enclosed by poor boundary treatments



Houses overlook blank garage walls in a tightly enclosed lane

**Good Practice**

Recommended minimum play area buffer zone separation standards.

Separation distances are measured between the edge of the activity zone and the boundary of the nearest dwelling.

- Local Area for Play (LAP): 5m
- Local Equipped Area for Play (LEAP): 10m
- Neighbourhood Equipped Area for Play (NEAP): 30m

N/B these are 'minimum' distances in association with the three categories of play areas defined under the 'Six Acre Standard'. Greater separation distances may be required depending on the size, extent and nature of the play area and the equipment or activities proposed.

Source: The Six Acre Standard:

**3.11.23 Public spaces and play areas**

*Outdoor spaces and play areas should be located on a through route/main line of movement, be well overlooked by surrounding dwellings without detriment to residential amenity and benefit from natural light*

**3.11.24** Outdoor spaces and play areas can add value in terms of character, interest, legibility and meeting the play and recreational needs of the residents.

**3.11.25** They are more likely to be used and less susceptible to anti-social behaviour where they are well overlooked by surrounding buildings, situated on main through routes (pedestrian or vehicular) that provide good accessibility as well as opportunities for casual overlooking and orientated to benefit from natural light.

**3.11.26** Natural surveillance from surrounding dwellings enhances safety, although this must be balanced with the amenity of the neighbouring occupiers to minimise the potential for disturbance.

**3.11.27** Outdoor spaces and play areas should be separated from adjoining dwellings by a suitable 'buffer zone'. The nature and extent of the separation buffer zone will be dependent on the uses

intended on the open space. Areas intended for ball games or noisy activities can cause particular annoyance and will require careful siting and greater separation from dwellings to prevent undue disturbance to residents.

**Successful places:**

- Provide public spaces and play areas with high levels of natural surveillance.
- Orientate frontages to face towards spaces and play areas and minimise the presence of rear or side boundaries.
- Include buffer zones to provide separation between public spaces, play areas and facing properties.
- Use planting/landform to enhance amenity by providing some visual separation without undermining natural surveillance.
- Locate public spaces and play areas where they will be sheltered but still benefit from natural light.
- Separate children's play areas from dogs with fencing, if required, but which does not obscure overlooking of the play area.
- Include lighting where appropriate.
- Identify future management arrangements to ensure appropriate maintenance takes place.
- Use larger spaces as an opportunity for planting larger trees with wider townscape benefits.



**Above:** Local play spaces situated close to homes, need to strike a proportionate balance between overlooking for safety and not being so close that neighbouring residents will suffer from noise and disturbance (Bottom Photo: Andy Cameron WSP).





**Left & below:** A neighbourhood square and play space is well overlooked by surrounding homes, while its central position is set away from immediate frontages to help maintain residential amenity.



Public spaces and play areas offer opportunities to incorporate distinctive features such as public art (Stone Tree image courtesy of Groundwork Creswell, Ashfield and Mansfield)



Permission to use drawing and photo courtesy of the Homes and Communities Agency



### Building for Life criteria

#### Integrating into the neighbourhood

**2. Facilities and services** Does the development provide (or is it close to) community facilities, such as shops, schools, workplaces, parks, play areas, pubs or cafes?

#### Creating a place

**5. Character** Does the scheme create a place with a locally inspired or otherwise distinctive character?

**6. Working with the site and its context** Does the scheme take advantage of existing topography, landscape features (including water courses), wildlife habitats, existing buildings, site orientation and micro-climates?

**7. Creating well defined streets and spaces** Are buildings designed and positioned with landscaping to define and enhance streets and spaces and are buildings designed to turn street corners well?

**8. Easy to find your way around** Is the scheme designed to make it easy to find your way round?

#### Street & Home

**9 Streets for all** Are streets designed in a way that encourage low vehicle speeds and allow them to function as social spaces?

**11 Public and private spaces** Will public and private spaces be clearly defined and designed to be attractive, well managed and safe?

## 3.12 Place Hierarchy

### 3.12.1 Place Hierarchy

*Proposals should provide a hierarchy of buildings and spaces to emphasise key locations within the layout and contribute to the character and legibility of the townscape*

**3.12.2** Historically, settlements comprised spaces and buildings in an order of visual and functional hierarchy. Places of importance looked important. Town squares, market places, village greens or a crossing of roads provided a social and economic focus for the community. They are often accompanied by buildings of some status, whose architecture and presence help reinforce the significance of the place.

**3.12.3** In some cases the original purpose of the place may have changed. However, focal spaces continue to perform an important townscape role and developments should include a hierarchy of both major and minor spaces, that are appropriate to the scale of the scheme.

**3.12.4** Ordinary, everyday buildings make up much of the remaining urban fabric (although this need not mean they are uninteresting in themselves) and they provide the backdrop to the wider built environment.

### Establishing a hierarchy of streets and places

Develop conceptual ideas with the view to creating interesting 'places' within the scheme

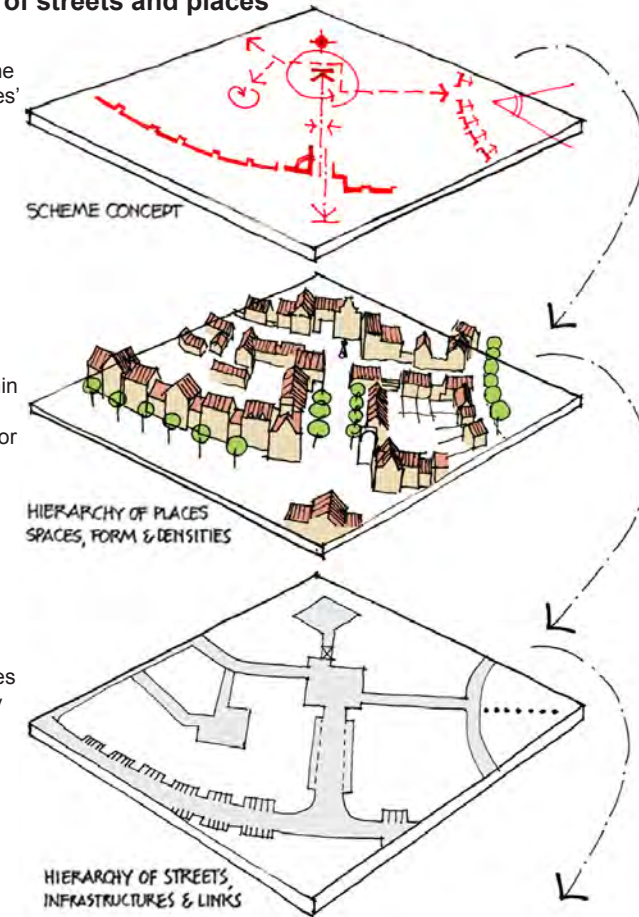

Create a hierarchy of places within the development that include major focal points as well as minor nodes by designing and siting buildings in a way that supports this approach

Streets between focal point places should also comprise a hierarchy of street typologies that support the development of places with character

**Below:** Houses arranged around a green in a village setting provides an appropriate focal point in this context



**3 Main Focal Point:** The illustration shows a square serving as a focus for the main routes. Larger buildings terminate long vistas on the approach to the square. The square could be designed as a shared space, with a central tree or public art installation. In larger schemes, some mixed uses and a bus stop may be appropriate.



**A place and street hierarchy for a scheme, supported by buildings that respond to the scale, significance or role of each street or place.**

**5 Minor Street:** These could serve lower density groups at the lower end of the hierarchy. Occasional tree planting dividing the carriageway can reduce speeding and incorporate parking, as appropriate.



**6 Mews Street:** Typically characterised by shared surfaces and aligned at right angles to secondary streets. They would be relatively short, with terraces incorporating garages and slightly set back from the designated roadway.



**4 Secondary Street:** These are the distributors of the scheme and each may have a somewhat different character. On-street parking could be incorporated into the street design. Typically two and 'two and a half storey' houses, mainly in short terraces would be located here. All would have relatively modest front gardens. Frequent junctions and changes in direction would contribute to speed reduction.



**7 Green Edge Access Way:** 'Single loaded' informal roadway serving houses fronting greenspace and possibly incorporating play space. Typically, the pavement would be on one side. In smaller schemes the roadway could be a shared space private (unadopted) drive.



**2 Main Street:** In the case shown, a formal tree-lined avenue of larger detached villas, set back behind front gardens. In other cases larger terraces may line the street. Due to its spinal route function, the street is likely to have the widest carriageway.



**1 Entrance or Gateway:** Buildings grouped to 'announce' the entrance to the scheme, either by a group enclosing a small green, or by buildings massed to give emphasis to the corner, depending on the existing context, or the character of the scheme.



**8 Courtyard Parking:** Small shared surface areas overlooked by flats over garages. These spaces would usually be located behind main frontages.

**3.12.5** This distinction between important and everyday spaces and buildings establishes an order of place hierarchy and is an important ingredient of any townscape. However, this must be 'tuned' to reflect the nature of the settlement so that spaces and buildings are appropriate to the scale, role and character of the place. Focal spaces and buildings of status will differ between a village and an urban setting.

**3.12.6** Residential developments often fail to capture this aspect of the townscape and standard house types are often unable to create the status and presence required to identify an important location. It is therefore necessary to find ways of introducing a built hierarchy into residential developments capable of fulfilling this townscape role.

**3.12.7** Important buildings punctuate the townscape, provide useful reference points and give emphasis to key uses, locations or notable corners. Often landmarks in their own right, they are important in helping people find their way around and making places understandable.

**3.12.8** Where buildings of status already exist (either within or outside the site) they should be integrated as part of the scheme, by either deferring to them, providing an appropriate setting or creating views.

**3.12.9** Designs should emphasise important locations within the development, by expressing its scale, architectural quality and materials. Even modest developments may require buildings that provide a focus.

**3.12.10** Where new spaces are provided they should be enclosed by buildings and designed to create a sense of place with active uses introduced within or around the space, wherever possible (mixed use developments).



Building scale, design and quality of materials convey status and identify this as an important location within this scheme



Designs should integrate with their context and defer to existing key landmarks. Creating a route/view to the church tower would form an important connection to this village



Distinctive architecture, scale and the careful placement of this building reinforce this square as an important place



A green containing a feature fountain provides strong focal point and sense of arrival



**Above:** Houses deliberately designed and sited in order to close views along these streets and provide minor visual focal points that both support character and assist legibility

#### Successful places:

- Contain a hierarchy of focal spaces and buildings that form part of network of public spaces.
- Locate focal spaces along main thoroughfares or where two important routes cross and are well overlooked.
- Design focal spaces that are proportionate in scale and character to their location and context.
- Ensure spaces are adequately enclosed by buildings, are accessible and create a focal point such as with a tree, building, public art or monument.
- Position buildings of status to reinforce the importance of focal spaces, emphasise key corners or to terminate views.
- Signal a building of status through its scale, positioning and special architectural treatment (quality, materials, detail and finishes).
- Recognise existing buildings of status within or visible from a site, by deferring to their setting or maintaining or creating views to such buildings.

**3.12.11** Building placement and architectural responses should be informed by both their context and their role within the place hierarchy. Buildings of greater stature, scale, richness and quality should be used to express the significance of important places, views and nodes to create 'impact' within the townscape and help differentiate one place from another.



### BUILDINGS WHICH TERMINATE VISTAS

The design of the building should recognise that:

- the elevation will be seen from a distance
- the massing, scale and roofline should respond to this focal role in the streetscape.



### KEY GROUPS

#### Focal Point Group

Informal massing at intersection of streets & pedestrian routes. Creation of a sense of place by sunny, sheltered space, active frontages/mixed uses, & attractive public realm.

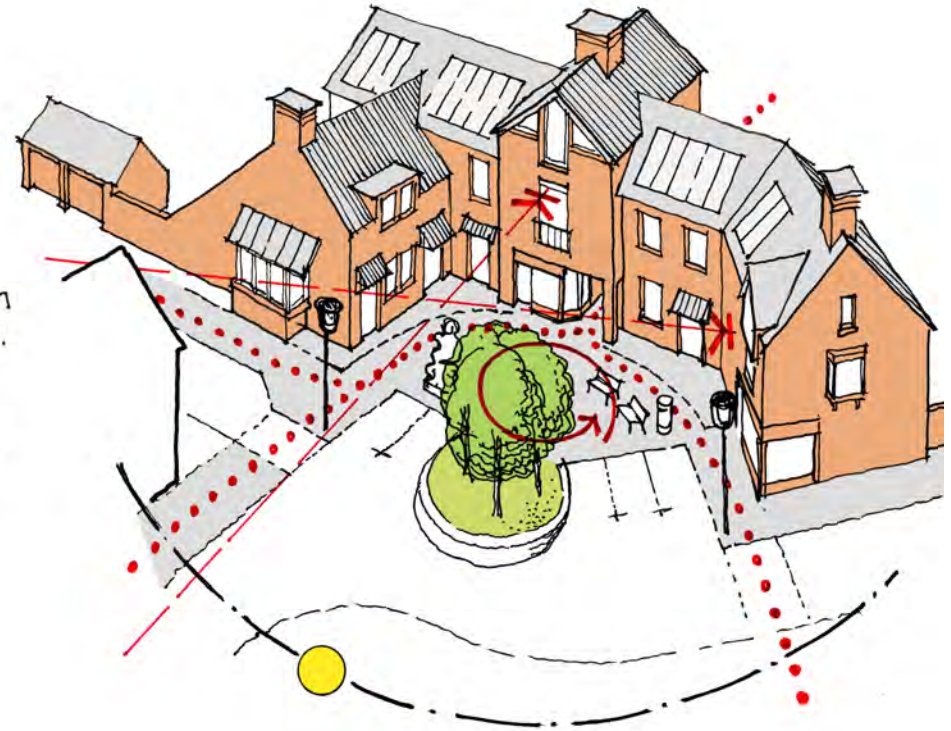

#### Gateway Group

Formal suburban example creating a spacious entrance 'funnelling' to a pinch-point. Bold gables relate to the scale of the 'green'.



Left: A building deliberately designed to respond to its role within the townscape by providing a minor focal point, closing the view along the street and assisting legibility



**Building for Life** criteria

**Creating a place**

**5. Character** Does the scheme create a place with a locally inspired or otherwise distinctive character?

**7. Creating well defined streets and spaces** Are buildings designed and positioned with landscaping to define and enhance streets and spaces and are buildings designed to turn street corners well?

**8. Easy to find your way around** Is the scheme designed to make it easy to find your way round?

## 3.13 Design for Corners

### 3.13.1 Corners

*Proposals should recognise the importance of corners and their role in the townscape designing corner buildings to respond appropriately to their unique location, while maintaining the occupants amenity*

**3.13.2** Corners play a special role in the townscape, occupying visually prominent locations and having two frontages addressing different streets. They can highlight key locations and serve as local landmarks, although if poorly conceived and implemented they can weaken the townscape.

**3.13.3** Corners pose particular design challenges in terms of achieving continuity to street frontages, articulation of junctions, providing practical garden spaces with adequate light penetration and privacy to gardens and windows. If these issues can be reconciled they have the ability to contribute significantly to the character and quality of the place.

**3.13.4** Corner houses should articulate the corner and address both frontages. Many standard house types are unable to achieve this satisfactorily. As such more bespoke

approaches to corner house types are likely to be necessary.

**3.13.5** Highlighting corners is best achieved by expressing height, the inclusion of prominent entrances and/or windows or using the buildings form, architecture and quality materials to provide emphasis. In mixed use schemes active ground floor uses can also be effective. Often two or more of these elements can be combined successfully.

**3.13.6** Within larger developments variation between corners is also necessary to avoid each one appearing the same and undermining their contribution to the legibility of the place.



A contemporary corner design gives emphasis to a building of traditional scale and form



A notable corner expressed through scale, height and roof form of the house

**Successful places:**

- Use building placement to define the space on the corner and maintain a good level of continuity to frontages.
- Articulate corners at prominent nodal points or junctions to emphasise important locations and assist legibility.
- Maximise opportunities for surveillance onto both frontages, while minimising the extent of blank frontages or walls.
- Provide a direct relationship between habitable rooms and gardens.
- Maintain privacy between the habitable rooms of homes within the corner.

## HOUSES WHICH TURN CORNERS

- Major corners are pivotal points in a townscape – between one space & another.
- A corner building is seen in 3 dimensions.
- It must be a minor focal point which addresses both streets with active frontages to the corner itself.

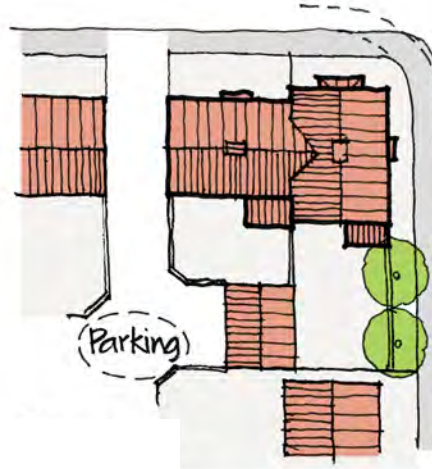
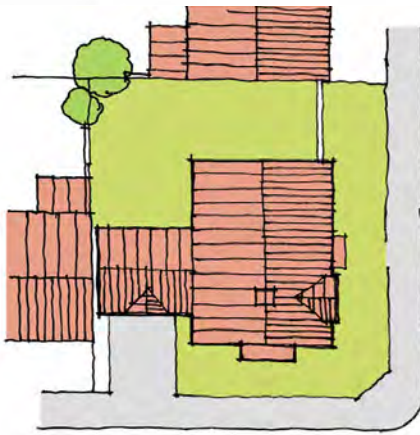

### Square Corner

Alternative layout for more compact contexts

Ensures:

- ▶ privacy
- ▶ minimal overshadowing
- ▶ adjacent parking
- ▶ positive corner



### Concave Corner

(could also be curving plan)

Allows for:

- ▶ large, sunny, private gardens
- ▶ extensions
- ▶ rear garages on plot
- ▶ spacious green frontage



### Convex Corner

Likely issues:

- ▶ overlooking
- ▶ overhearing
- ▶ overshadowing
- ▶ smaller gardens



A house type designed to handle a corner and address both frontages (Davidsons Group Ltd)



A house uses a gable with distinctive windows and local stone to express the corner (Image Courtesy of Walker Troup Architects)



Corners emphasised by height and architecture identify an important node and aid legibility



### Building for Life criteria

#### Character

##### 7. Creating well defined streets and spaces

Are buildings designed and positioned with landscaping to define and enhance streets and spaces and are buildings designed to turn street corners well?

##### 8. Easy to find your way around

Is the scheme designed to make it easy to find your way round?

#### Street & Home

##### 11 Public and private spaces

Will public and private spaces be clearly defined and designed to be attractive, well managed and safe?

## 3.14 Frontages

### 3.14.1 Public Fronts

*Building frontages and entrances should be orientated to positively address the street*

**3.14.2** Front and back spaces perform different roles and this should be reflected in their design. Orientating main facades to face towards the street gives a public face to the building and creates a positive relationship between public and private realm. Active frontages with doors facing towards the street and overlooking windows provide passive surveillance and make it feel safer.

**3.14.3** The main entrance to the building should be located on the front elevation and be clearly visible from the street. This generates movement adding vitality to the street, whereas side entrances are less visible and potentially more vulnerable.

**3.14.4** Where possible, internal house layouts should be arranged with some rooms requiring less privacy positioned at the front. This enables occupants to relate to the street and overlook and interact with the outside.

#### Successful places:

- Arrange buildings to face towards the street with clearly visible entrances.
- Create active frontages with windows and frequent entrances providing direct access to the street.
- Arrange living spaces requiring less privacy to face towards public frontages.
- Design windows to maximise overlooking, putting 'eyes on the street' without compromising privacy.
- Avoid or minimise blank elevations or limit their extent against public frontages.



A clear entrance that relates well to the street



A living room located at the front enables a relationship with the street and provides security through overlooking



Contemporary town houses relate to the street with clear entrances and multiple windows providing surveillance of the street



Largely blank ground floor elevations deaden the street scene and limit surveillance of public areas



“...all buildings have two faces: a **front** onto public space, for entrances and the most public activities, and a **back** where most private activities can go.”

Responsive Environments,  
Bentley *et al* (2005)

### 3.14.5 Private Backs

## Private space should be clearly defined and enclosed to provide privacy and security

**3.14.6** Private spaces require both privacy and security. They should be clearly defined, usually by enclosure to distinguish between the public and private sides of the building.

#### Successful places:

- Provide a clear distinction between public, semi-public and private spaces with clearly defined boundaries.
- Arrange living areas requiring privacy to face private spaces.
- Arrange rear gardens to face onto rear gardens.
- Generally avoid or limit rear access paths to gardens. Where necessary, any paths should be short, direct, serve a small number of properties, and can be accessed via a single point of entry which is overlooked.
- Provide shared private spaces for flats at the back and preserve the amenity of adjacent ground floor dwellings.

**3.14.7** Rear gardens which back onto other gardens are generally more secure than those with separate rear access or those backing onto parking courts. Where shared gardens or other communal spaces are provided (such as for flats), the buildings should help define the edges of the space. The privacy of ground floor flats should be maintained by private yards or gardens with clearly defined boundaries, where possible.

**3.14.8** Rooms requiring privacy such as bedrooms or bathrooms are normally best located at the rear of dwellings as they generally provide limited overlooking of the street.

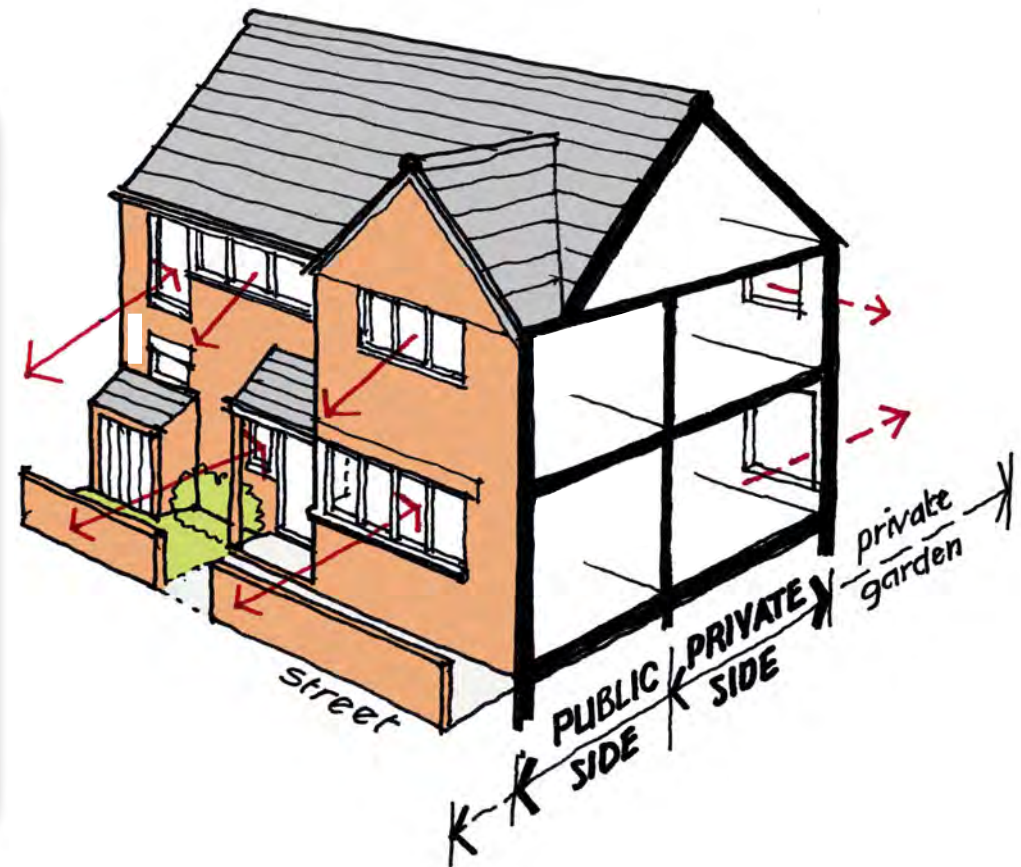

### 3.14.9 Continuity

*The continuity of the street should be informed by its context, character and role within the development*

**3.14.10** The way frontages are arranged plays an important role in defining the character of the townscape and distinguishing between public and private areas. Frontages that provide continuous building lines create a cohesive edge to the street.

**3.14.11** Where buildings cannot be joined directly, semi-continuous frontages can be achieved by linking houses, outbuildings and garages using connecting walls. Building lines can potentially also be set-back or projected forward to create emphasis or visual interest, if required, while maintaining its continuity.

**3.14.12** It may not always be appropriate to provide continuous frontages and strong building lines. Some village settings, settlement edges or low density locations may require a softer, loose knit pattern of development where the built form is a less dominant element of the street scene. An assessment of the context will help inform the appropriate approach.

**3.14.13** The continuity of the street should be informed by its context, character and function within the street/place hierarchy.

#### Successful places:

- Reinforce and define the street by relating buildings to a common building line.
- Vary the degree of continuity according to context and character.
- Utilise set-backs to soften the building line and projections to create visual interest or emphasis to a building or location.



A continuous building line clearly defines the frontage



A loose knit semi-continuous frontage



A semi-continuous frontage creates enclosure by siting houses towards the front of the plot (Courtesy of Davidsons Group Ltd)



A village infill site with an informal character and loose knit pattern of development. Here a strong building line and continuous frontage would be inappropriate.



A continuous street frontage creates a clearly defined edge to the space



Informal organic frontages in a village setting

## FRONTAGE LAYOUT OPTIONS



Regular/flush/continuous



Regular/shallow projections



Indented



Discontinuous

Building Line

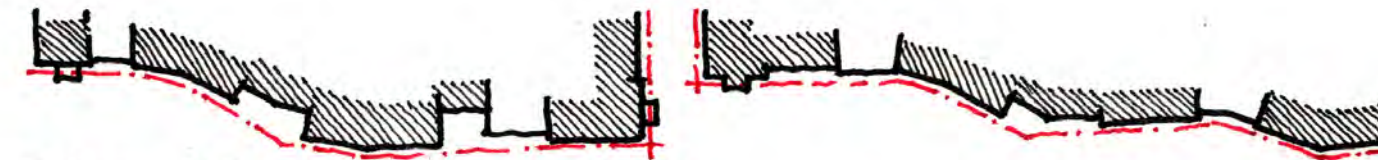

Informal/organic semi continuous

**Right:** The layout of frontages can have a major influence on the degree of enclosure and the character of the street



**Building for Life** criteria

**Character**

**5. Character** Does the scheme create a place with a locally inspired or otherwise distinctive character?

**7. Creating well defined streets and spaces** Are buildings designed and positioned with landscaping to define and enhance streets and spaces and are buildings designed to turn street corners well?

**8 Easy to find your way around** Is the scheme designed to make it easy to find your way round?

**Street & Home**

**11 Public and private spaces** Will public and private spaces be clearly defined and designed to be attractive, well managed and safe?

## 3.15 Enclosure

### 3.15.1 Street Enclosure

*Streets and spaces should be enclosed by appropriately scaled buildings*

**3.15.2** Streets and spaces are defined by the buildings at their edges. Their level of enclosure is determined by the width of the space and the relative height of the adjoining buildings.

**3.15.3** Enclosure influences the character of a place and contributes to its sense of place. Good enclosure is achieved by ensuring that the height of the adjoining buildings is proportionate to the size and significance of the street or space.

**3.15.4** Tightly enclosed spaces will have an intimate character. Larger and more important spaces generally require larger buildings to adequately enclose them. Whereas large spaces enclosed by small buildings appear weakly defined, often lack containment and a sense of place.

**3.15.5** The scale of buildings and the width of the street contribute to legibility by reinforcing the relative importance of key places and routes within the overall place hierarchy.

**3.15.6** The level of enclosure also needs to be considered in relation to what is appropriate in the context as well as amenity e.g. loss of privacy, light and over-dominance.

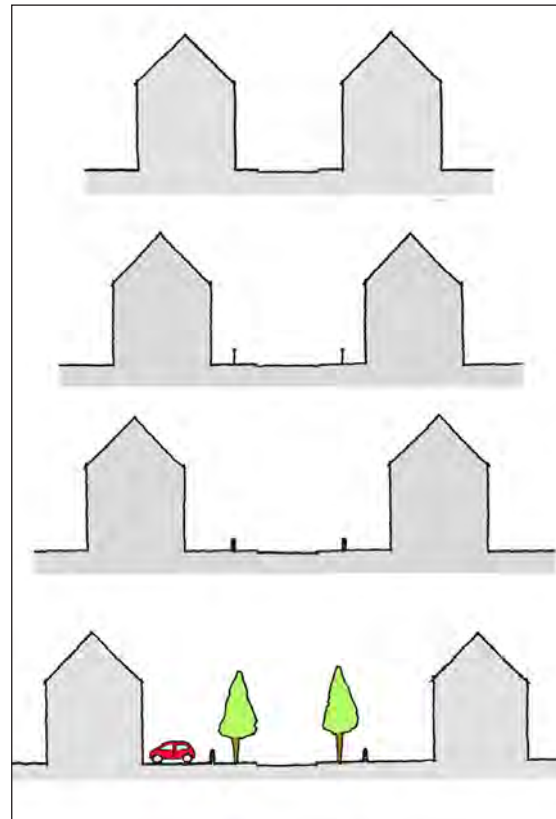

An 8.8m wide highway (carriageway and footways) shown with varying degrees of enclosure. Adjustments to building set-backs, the presence of boundaries, street trees and changes in building heights can all contribute to the relative degree of enclosure and influence the street character



Narrow streets tightly enclosed by adjoining homes but with differing characters

**Successful places:**

- Define streets and spaces by enclosing them with appropriately scaled buildings.
- Consider the design of streets, spaces and buildings as a whole rather than as separate elements.
- Use enclosure to help define character, reinforce legibility and reflect the place hierarchy of the street.
- Avoid or minimise negative impacts on residential amenity.

“Our interest is in ‘urban architecture’ – that is buildings and open space considered as a totality.

Urban Design Compendium 1 (2007)

### 3.15.7 Boundaries

*Boundaries should be appropriate to their location, strengthen distinctiveness and reflect the characteristics of the local context*

**3.15.8** Where buildings are set back from the street the plot boundary should be clearly defined. A clear vertical boundary provides a good distinction between public and private space and supports privacy by creating a defensible area between the dwelling and the street.

**3.15.9** Boundary treatments can also have a significant influence on local distinctiveness and character. Local materials, details and traditions can make a big difference to the look and feel of the place, whereas inappropriate boundary treatments can undermine its character.

**3.15.10** The nature and materials of front boundary treatments should reflect the context and character of the setting. Urban locations will have urban types of boundary treatment, like railings. Rural areas will have boundaries like stone walls and/or hedges.

**3.15.11** Timber fences to frontages, or in visible gaps between buildings or on exposed flanks form less robust boundaries, are generally uncharacteristic in most settings and should normally be avoided.



A beech hedge provides an informal boundary treatment with an appropriate character given the setting of the house against a village green



Railings can be appropriate in both urban and rural settings and softened by combining with hedging

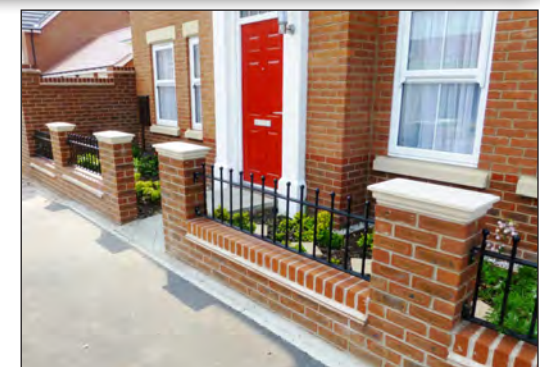

Modest brick walls and railings reflect their context and provide defensible space to small front gardens

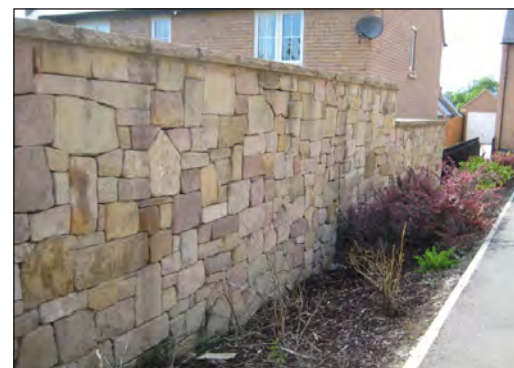

A visible side wall on a corner plot is finished in local stone to a high standard



A hurdle fence in a rural setting provides a rustic boundary between plots where this is visible from the street

#### Successful places:

- Provide robust boundary treatments to create defensible spaces that distinguish between public and private realm.
- Vary boundary treatments according to the context and its characteristic edges.
- Draw on local traditions, materials and detailing to strengthen local distinctiveness.
- Avoid lower quality or inappropriate functional boundary treatments in prominent positions like visible front or side boundaries.

### 3.15.12 Set-backs

*Set-backs from the building line should be determined by the location, context and character of the setting*

**3.15.13** Set-backs provide a semi-private space between a dwelling and the street, strongly influencing its character and level of enclosure. They can also have a role in meeting a dwellings' storage and servicing requirements. To integrate with its context new development should normally reflect the established building line.

**3.15.14** Town or village centres may have direct access to the street with little or no set back. Inner urban areas often include modest front gardens (1.5 – 4m) providing a defensible space while maintaining good surveillance of the street as well as opportunities for personalisation. In suburban settings or adjacent to busier roads more generous set-backs (4 - 6m) are generally acceptable, providing greater separation and scope for off-street parking. In more rural or low-density settings these may be increased further if this is appropriate to the context.

**3.15.15** Development close to an existing busy and noisy route may need greater separation to assist in mitigating against noise and disturbance from traffic.

#### Good Practice



Indicative set back distances by location:

**Central** (town / village centre): minor or no set back

**Inner Urban:** 1.5 – 4m

**Suburban:** 4 - 6m

**Rural / very low density:** 6m+ acceptable

Adapted from Urban Design Compendium 1 (2007)

#### Successful places:

- Use set-backs to help positively define the character of the street, where appropriate to the character of the place.
- Discretely accommodate storage and servicing requirements.
- Use set backs to provide defensible space.
- Have regard to privacy in the design and layout of ground floor rooms.
- Give careful attention to the design of entrances and thresholds.

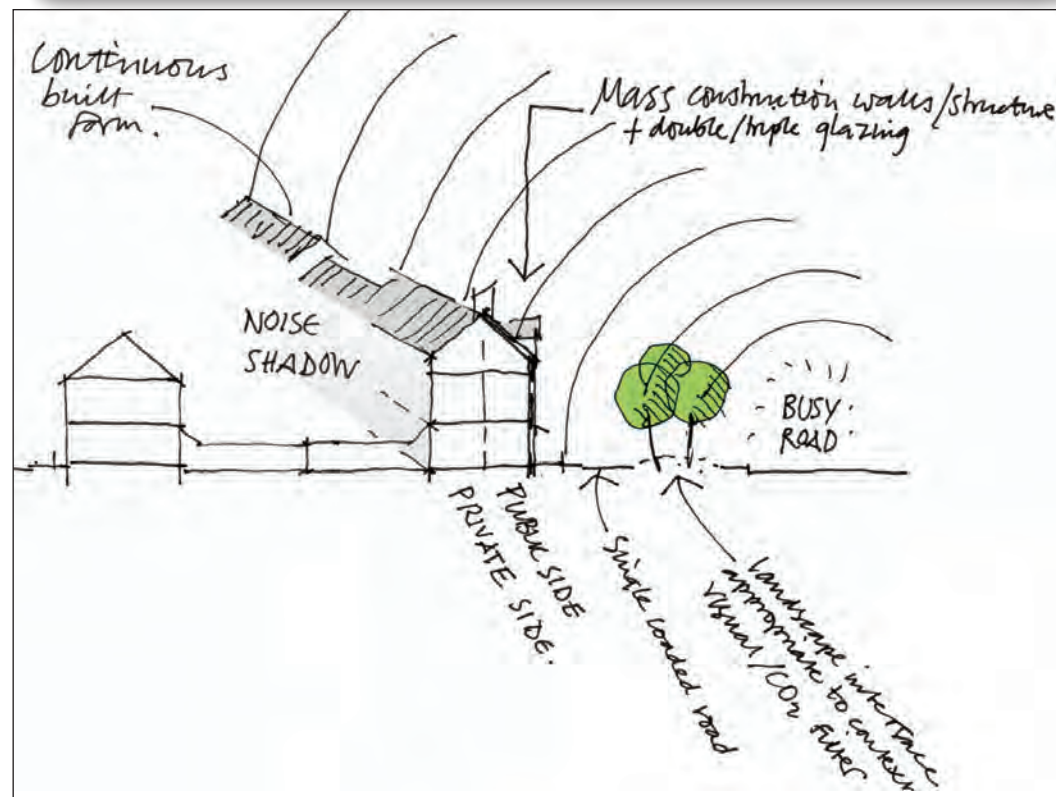

A continuous building line set back from an existing busy road to mitigate against noise and disturbance



An urban street with no set-back from the footway



A central village development with a minimal set-back and robust boundary walls



A suburban setting with deep set-backs, frontage parking and open plan frontages with no enclosure

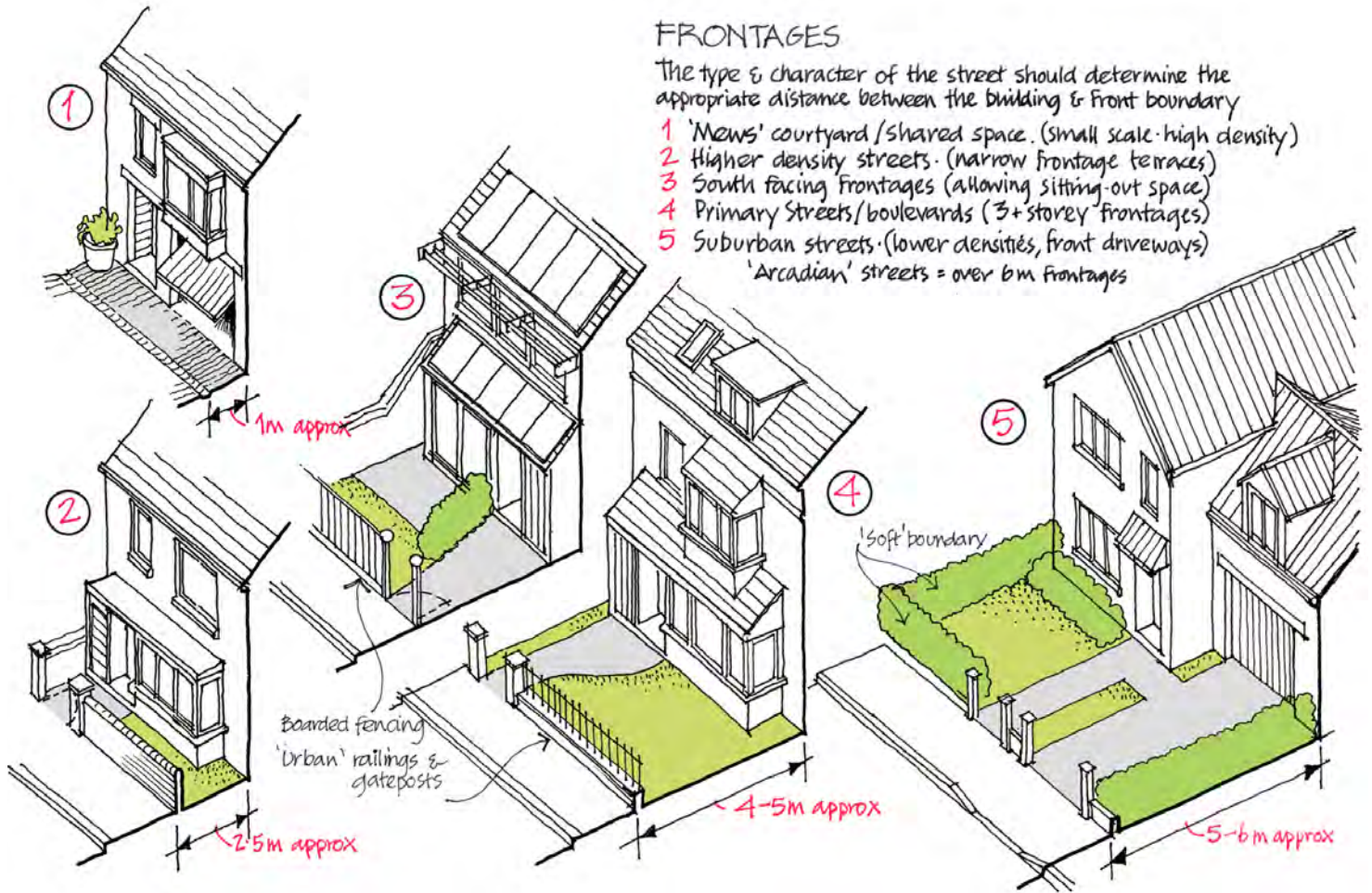

A new village style street with minimal set-backs and distinctive character



Mature trees heighten the sense of enclosure where buildings are set back from the street



### Building for Life criteria

#### Creating a place

**5. Character** Does the scheme create a place with a locally inspired or otherwise distinctive character?

**6. Working with the site and its context** Does the scheme take advantage of existing topography, landscape features (including water courses), wildlife habitats, existing buildings, site orientation and micro-climates?

**7. Creating well defined streets and spaces** Are buildings designed and positioned with landscaping to define and enhance streets and spaces and are buildings designed to turn street corners well?

**8. Easy to find your way around** Is the scheme designed to make it easy to find your way round?

#### Street & Home

**11 Public and private spaces** Will public and private spaces be clearly defined and designed to be attractive, well managed and safe?

**12 External storage and amenity space** Is there adequate external storage space for bins and recycling as well as vehicles and cycles?

#### Sustainable?

*Code for Sustainable Homes:* Building to high levels of the Code for Sustainable Homes will achieve sustainable building forms across a range of 9 performance criteria. Currently only the *Energy* part of the Code is mandatory under the Building Regulations.

## 3.16 Building Design

### 3.16.1 Respect the Context

*Building forms and details should be appropriate to the local context, their position and role within the place hierarchy and make a positive contribution to the character of the place*

**3.16.2** Buildings should be designed with sensitivity to their setting within the local context. They will form part of an existing place and must respect the local characteristics and neighbouring buildings, enriching the quality of the place.



Contemporary infill housing that respects the scale, form and materials of the local context

#### Successful places:

- Respect the continuity of the building line.
- Use simple designs similar to local buildings in respect of their forms, heights, widths, scale and proportions.
- Are built from or in harmony with local building materials.
- Reinterpret local building types in a way that contributes to the distinctiveness of the place.

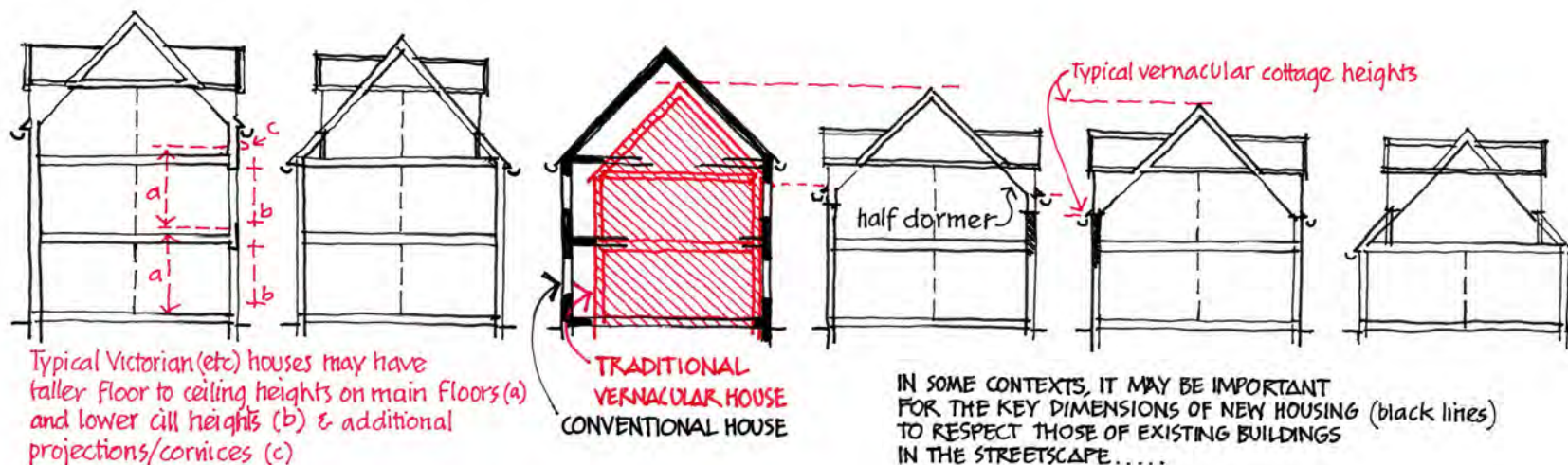



### 3.16.3 Building Forms

*Building and roof forms should be appropriate to their setting and function and support the creation of streets with character*

**3.16.4** The plan form of the building influences how it can be arranged within the street and block.

**3.16.5** Wide-fronted, shallow-plan buildings can be arranged with flexibility and are capable of providing both continuous frontages with varied street layouts. These forms are often associated with vernacular styles in rural/village locations and can create streets with a more informal, organic layout.

**3.16.6** Narrow fronted, deep-plan buildings are efficient in terms of land use and preventing heat loss. They are often associated with urban settings and are suited to creating terraces, straight streets and formality, but are less suited to creating varied layouts.

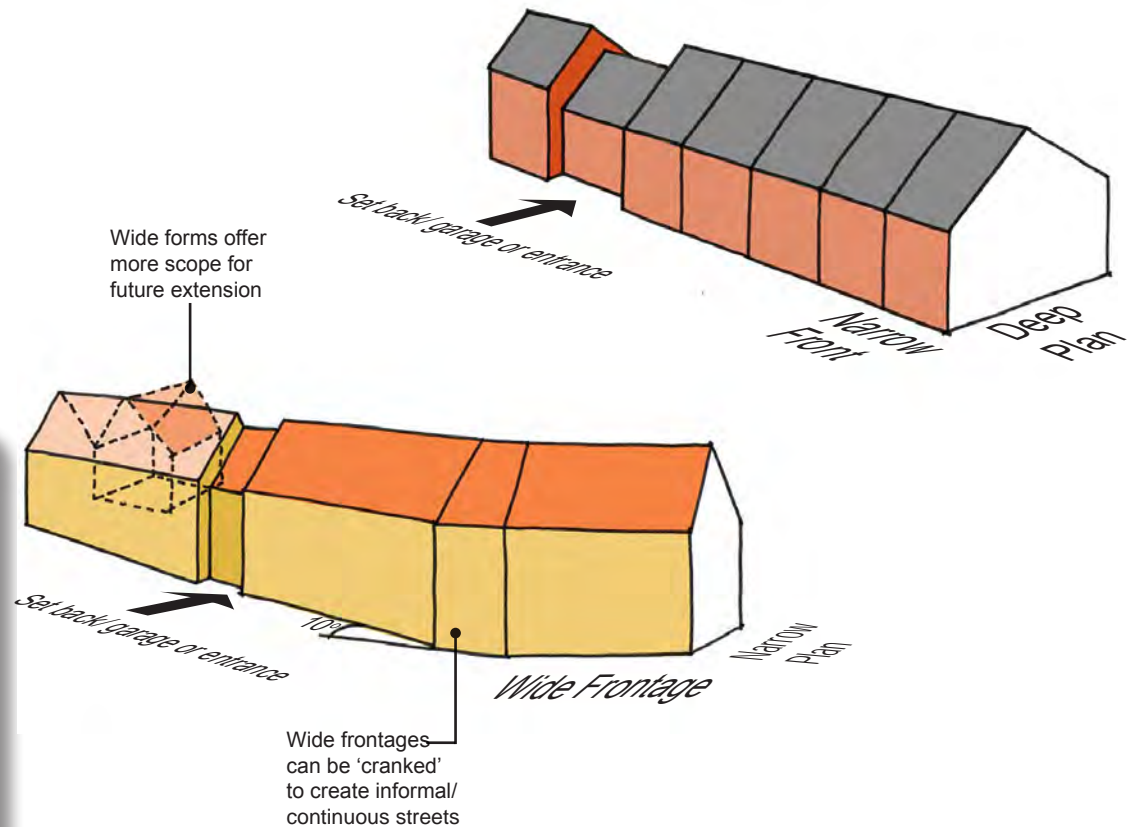

#### Successful places:

- Utilise building forms that create clear definition and enclosure of the street.
- Use building and roof forms to create character and reflect their context or if appropriate wider setting.
- Utilise forms that support the townscape role of the building.
- Normally, avoid shallow roof pitches (less than 35 degrees) or over dominant roof forms and dormer windows.

#### Sustainable?

##### Efficient forms:

Flats and terrace building forms are more thermally efficient, having less external surface area from which to lose heat.

Semi-detached and detached house types are least efficient in terms of heat loss.

Where units are joined, designing out noise transmission is crucial in order to minimise disturbance and maintain residential amenity and quality of life.

**Good Practice**

Depending on the scale and context of the development the range of house types needed to reflect different locations within the street and place hierarchy is likely to include the following:

**Linked dwellings** that can be joined to form coherent streets and enclosed front-ages.

**Scale, height & form** used for houses intended to enclose spaces or terminate views.

**Corner houses** that address key corners with active frontages on both streets.

**Key groups** that can be arranged to give emphasis to important locations.

**Mews** homes or flats over garages, for use in rear parking courts, narrow or awkward locations or to provide cross streets within larger blocks.

**Single aspect dwellings** where circumstances restrict residential outlook (limited use only).

**Apartments** for higher density locations.

**3.16.7 Building types and role**

*Buildings that perform important townscape roles should be designed and detailed to a standard that reflects their status*

**3.16.8** The composition of a building's elevation and its components will determine the appearance, richness and interest of individual façades. This should reflect both the context (see above) and the role the building plays within the place hierarchy, such as visual stops, landmarks and buildings enclosing focal point spaces.

**3.16.9** Greater attention to detail, higher quality architectural design, richness and materials will be appropriate for key buildings and focal points to signify their visual and townscape importance. This is not to say that other buildings should be of poor quality.

**3.16.10** Standard house types are often not suited to fulfilling different townscape roles and are often used with little regard to their contribution to place making and character, resulting in 'anywhere' developments.

**3.16.11** It is therefore essential that if standard house types are proposed that these can be responsive to the place, its context and character. This means designing house types that are

capable of adaptation to respond to different positions within the street/place hierarchy and reflect the townscape character of the local context. Standard designs from elsewhere will rarely be acceptable without appropriate adaptations.

**3.16.12** Over-reliance on a limited number of standard house types should normally be avoided. A range of variant house types will normally be required that are capable of fulfilling different townscape roles and contributing to the distinctiveness and interest of the place.

**Successful places:**

- Use architecture and form to express the status of key buildings and spaces.
- Carefully site buildings to support the legibility and hierarchy of the townscape.
- Use height, scale and form that is proportionate to the role and townscape status of the building.
- Use of high quality materials, design and detailing.
- Use house types that are capable of adaptation and respond to and reflect the character of the local context.



Height, scale, materials and architecture express the status of this building as an important element within the townscape



A key group of buildings work collectively to define the space and create a place within the development



A simple gable in a prominent townscape position is elevated by the addition of a strong chimney and well-proportioned gable windows

### 3.16.13 Appearance

*Buildings should provide a visually harmonious composition, informed by their context and should display architectural integrity*

**3.16.14** Good architecture brings together proportions, materials, colours and details to create a harmonious appearance. It is not about personal taste but the successful coordination of materials and architectural elements. The focus should be on design quality regardless of style.

**3.16.15** Proposals will normally be expected to harmonise with their surroundings, particularly where a distinctive or prevalent character exists. Designs that depart from the prevailing pattern of development will only be acceptable where these can be explained and justified by complementing or enhancing their setting.

**3.16.16** Proposals intended to reflect historic styles or details should retain the scale, proportion and integrity of the original and avoid incoherent and unconvincing copies. Mixing architectural styles results in disjointed and inappropriate designs and should normally be avoided.

**3.16.17** More contemporary approaches should draw on locally distinctive materials and elements and reinterpret them in a way that provides a connection to the place and avoid 'anywhere' developments.

#### Successful places:

- Are informed by and complement their context.
- Are visually harmonious whether contemporary or traditional in design.
- Avoid the arbitrary mixing of architectural styles.
- Possess architectural integrity and avoid using inappropriate or superficial devices.
- Draw on locally distinctive materials and qualities to ground them in their context.



**Above:** New homes with both contemporary and traditional appearance, respect the scale, traditional building forms and local materials of the existing adjoining townscape

*The details are not the details.  
They make the design.*

Charles Eames, Architect

### 3.16.18 Detail and richness

*Proposals should provide detail and architectural richness that is appropriate to the role of the building at a scale that reflects its status*

**3.16.19** Details are as important as the large-scale decisions about layout or movement. A lack of attention to appropriate detail can spoil an otherwise well designed scheme and undermine its quality. Details should be considered as an integral part of the building design not as superficial additions.

**3.16.20** Where places comprise simple forms with restrained detailing, simple and subtle detailing would be appropriate. This does not mean paring down the details to achieve cost savings, but is about doing those simple details well.

**3.16.21** The individual elements of a façade provide visual contrasts and relief (e.g. windows, doors, decorative details). These elements can themselves be enriched (e.g. windows with lintels and cills, brick detailing such as corbelling to eaves and verges, decorative door surrounds etc.) adding further layers of interest to a building as well as reflecting locally distinctive details and building techniques.

**3.16.22** Highly visible buildings (e.g. terminating a view) require larger scale elements

that can be seen from afar and small scale richness that will be seen close up. The detail should be proportionate to the role and position of the house in the place hierarchy.

**3.16.23** The individual elements that make up a building collectively influence the quality of its design. Each component must itself be well designed and arranged as part of a coherent composition. Detailed building elements should be relevant to their context rather than crude stick on additions or standardised 'one size fits all' solutions. Drawings of details may be sought as part of a planning application or required by condition.



**Above and left:** An important building contains large scale elements that can be appreciated from a distance but which also provide visual richness close up



**Above & right:** Simple details done well

#### Successful places:

- When using standardised components, make use of the range available rather than repetition of a single element.
- Use contextual clues to develop richness, taking cues from locally distinctive details, traditions and craftsmanship.
- Recycle craftsmanship - where present on site, salvaging and re-using elements of richness from the past, which would otherwise be unaffordable.
- Develop richness at different scales for prominent focal point buildings or those seen at longer distance.
- Ensure windows and doors have sufficient recess to add depth, articulation and avoid flat facades.
- Avoid crude, inauthentic or superficial additions.

#### Useful reference:



Responsive Environments  
Bentley *et al*, (2005)

### 3.16.24 Entrances and access

*Entrances should reflect the status and townscape role of the building, draw attention to the way in, be accessible and safe*

**3.16.25** Entrances are a major design element of any building. They create the first impression and are experienced by all visitors and users. They identify the way into the building and can also make an important statement about its status and townscape role.

#### Successful places:

- Locate main entrances primarily on front elevations.
- Ensure entrances are appropriate in scale and appearance to the building and reflect its status and townscape role.
- Provide entrances that are visible and accessible with reasonable gradients and an appropriate landing area.
- Ensure front doors are given greater prominence than garage doors.
- Provide safe routes between dwellings and any associated parking.
- Are well lit for comfort and safety.



A well detailed door and surround provides an attractive and legible entrance to this home



An attractive quality canopy and door relate to the street while a level threshold affords access for all

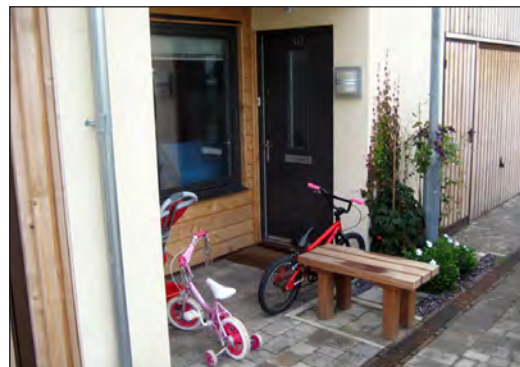

A recessed entrance provides an overlooked, level, sheltered porch as well as a social space

### 3.16.26 Aspect

*Buildings should be orientated to ensure that there is sufficient light to habitable rooms and gardens and occupants have a pleasant outlook*

**3.16.27** A dwellings aspect and the direction its windows or rooms face affect the internal living conditions, influencing the amount of sunlight and daylight to habitable rooms and gardens as well as the quality of the outlook.

**3.16.28** Single aspect and back to back dwellings are unlikely to be acceptable and should normally be avoided. If they face south and west they will be liable to overheat (unless the building is specifically designed to counter this) resulting in an uncomfortable internal environment. If the aspect is north-facing then habitable rooms would never receive direct sunlight.

#### Successful places:

- Avoid or minimise reliance on single aspect dwellings in any scheme and avoid north only facing units.
- Arrange most units to be dual aspect.
- Ensure reasonable levels of daylight to habitable rooms and garden areas.



## Building for Life criteria

## Street &amp; Home

## 12 External storage and amenity space

Is there adequate external storage space for bins and recycling as well as vehicles and cycles?

## 3.17 Adaptability

**3.17.1** Adaptability should be considered as part of the design process. Homes should be capable of meeting the changing needs of their occupants' as they age, have children, or use their homes in different ways. This may mean accommodating the needs of a growing family by having somewhere suitable to store a pushchair, providing a space for study or home working, or making adjustments to cope with infirmity or disability.

**3.17.2** Choices made early on in the design process and the method of construction have important implications on a buildings' adaptability. Future-proofing homes by making them adaptable is inherently sustainable and beneficial for individual householders and communities.

**3.17.3** Adaptations usually take the form of either enlargement or internal alteration to suit a particular need. Large floor spaces are generally the most adaptable allowing alternative internal arrangements.



Lifetimes Homes in practice - a cloakroom with pre-installed drainage to allow later conversion to a wet room

### Good Practice: Lifetime Homes Standard



Lifetime Homes is a standard that promotes accessibility and inclusivity in residential design. It comprises 16 criteria that provide a framework for creating both accessible and adaptable homes by enabling occupants to maintain their personal independence.

The Standard anticipates the likely future requirements of occupants and ensures that homes can be adapted over time to meet the range of people's needs at different stages of life, whether parents with young children or those with mobility difficulties associated with age or disability.

The practical nature of the Standard and the enhanced accessibility provided by Lifetime Homes means that they are helpful in many aspects of everyday life, not just those with more specialist needs. For example, hallways must achieve a minimum width and electrical switches and sockets must be sited in more accessible positions.

Developers are encouraged to build to the Lifetime Homes Standards wherever possible.

### 3.17.4 Extensions

*The potential for a dwelling to be extended should be a consideration at the design stage providing this would be appropriate to the character of the development and its context*

**3.17.5** Houses with adequate internal space will be less likely to require extension. However, the ability of a building to be extended should be a consideration at the design stage. Terraces and closely spaced semi-detached house types are less able to be extended without compromising neighbour amenity or visual appearance.

#### Successful places:

- Allow for the potential future extension.
- Adjust the scope for extension according to the character and density of the development and its context.

N/B The Lifetime Homes Standard is only mandatory under the Code for Sustainable Homes when building for Code Level 6 (under Category 7: Health and Well-being). At lower levels of the Code, building to the Lifetime Homes Standard is discretionary.

“A Lifetime Home is a home that will not evict its occupants through changing circumstances.”

Habitat Housing Association  
www.lifetimehomes.org.uk

### 3.17.6 Roofs

*Wherever possible roof spaces should be designed to allow for future conversion into additional accommodation*

**3.17.7** Homes with pitched roofs can potentially be converted to provide extra accommodation. This can be facilitated and made more cost effective if the design and construction allows for this possibility from the outset. Measures include an appropriate pitch to provide adequate headroom, non-trussed roof rafters, joist specification that requires minimum reinforcement and the space and layout able to provide an accessible staircase into the roof space. Future conversion would require compliance with the relevant Building Regulations.

#### Successful places:

- Make sure the construction and geometry allow for easy conversion to a usable space.
- Plan to allow for future fire protected stair access into the roof space.
- Provide adequate height to roof spaces to enable the correct headroom to be achieved.
- Minimise structural constraints such as trussed roof construction methods and include adequate strength to floors for minimal reinforcement.

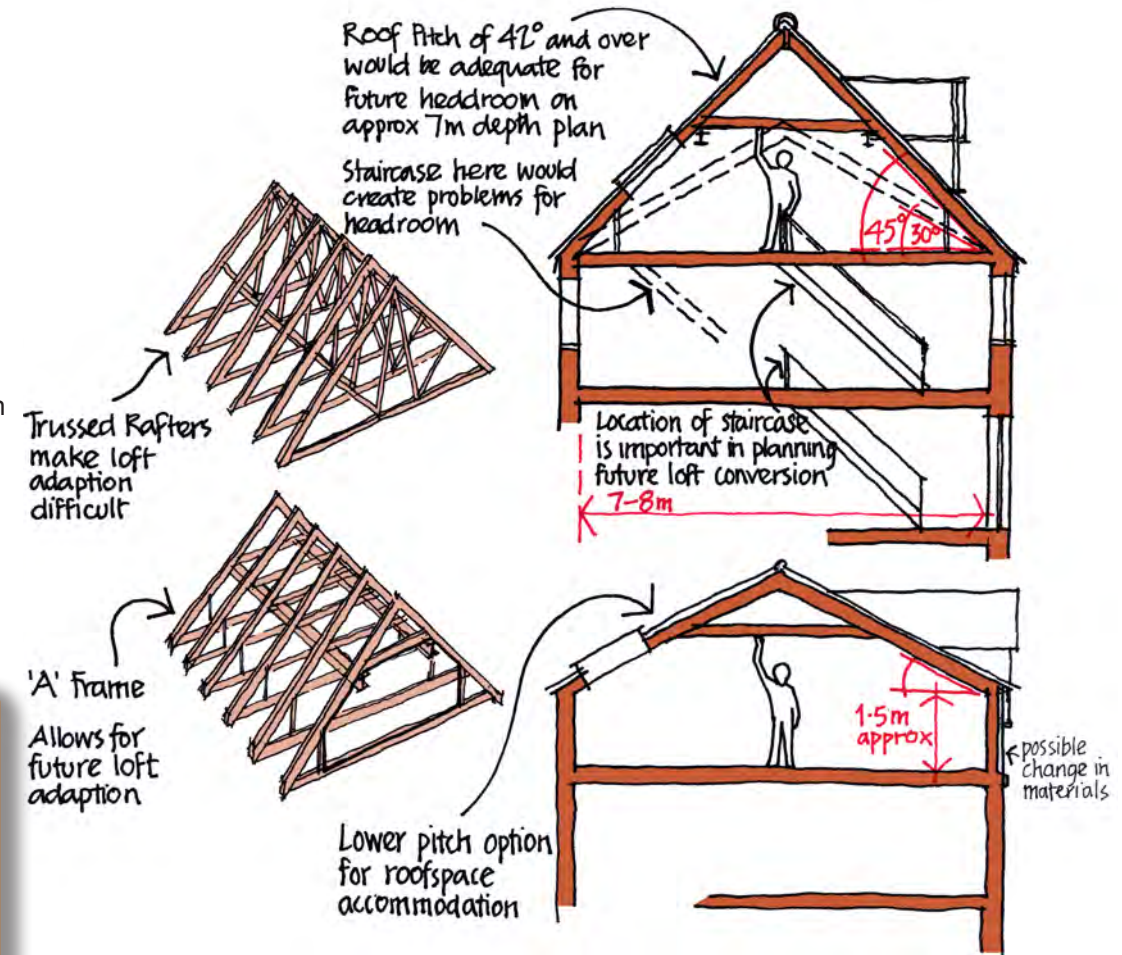

### 3.17.8 Potential for mixed uses

*In locations where a mixed use function is required or anticipated, a proportion of residential units should be designed to allow for their potential future conversion to non-residential uses*

**3.17.9** Where a site is large enough to provide a neighbourhood centre, or in locations where a mixed-use function is expected or desirable in the future, designs should anticipate the potential demand for commercial uses and ensure buildings are capable of conversion to business activities appropriate to a residential area. Single-use blocks will be difficult to adapt in future if this is not considered early on.

**3.17.10** The introduction of small-scale, non-residential uses within a larger development can be constrained by the phasing of a scheme. If small-scale commercial uses are unable to be provided early on in the life of a development, designing buildings that are capable of conversion provides a way of incorporating suitable business uses at a later stage.

**3.17.11** Likely suitable uses to meet local needs may include convenience shops, small offices, estate agents, pharmacies, hairdressers, hot food outlets, cafes, dentists, surgeries, vets etc. Deliveries, waste storage and removal need to be

considered, possibly via a rear service access. Front service access may be acceptable depending on local highway conditions, visual impact and amenity.

**3.17.12** Three main factors influence the ability of a building to adapt for change of use.

1. Building depth (affects the provision of natural light, ventilation and any required storage capacity).
2. Access and servicing (affects whether a building can adapt to other uses).
3. Building and ceiling height (floor to ceiling heights particularly at ground floor to allow for suspended ceilings for services).



A house designed to include a corner shop unit

	Typical	Minimum
Width of frontage	5.4 – 6m	4.0 m
Depth	-	12 m
Height (depending on services)	3.0 – 3.8m	2.8 m
Sales : ancillary ratio	50:50	45:55
Staff facilities – likely requirements	1 w.c. & basin (per sex), Changing area, lockers. Rest room & food prep area.	

**Table 5** Typical small retail / office dimensions

#### Successful places:

- Provide increased floor to ceiling heights, particularly at ground floor level, to accommodate the requirements of commercial services.
- Have the potential to provide separate entries from the street to upper floors to enable the vertical mixing of uses within buildings.
- Allow for universal access, including for people with impaired mobility.
- Incorporate good acoustic insulation between units and activities.
- Provide for adequate servicing by vehicles for deliveries, waste storage and collection.
- Configure internal spaces to allow uses and circulation to be easily adapted and use construction methods that enable such changes to be easily implemented.



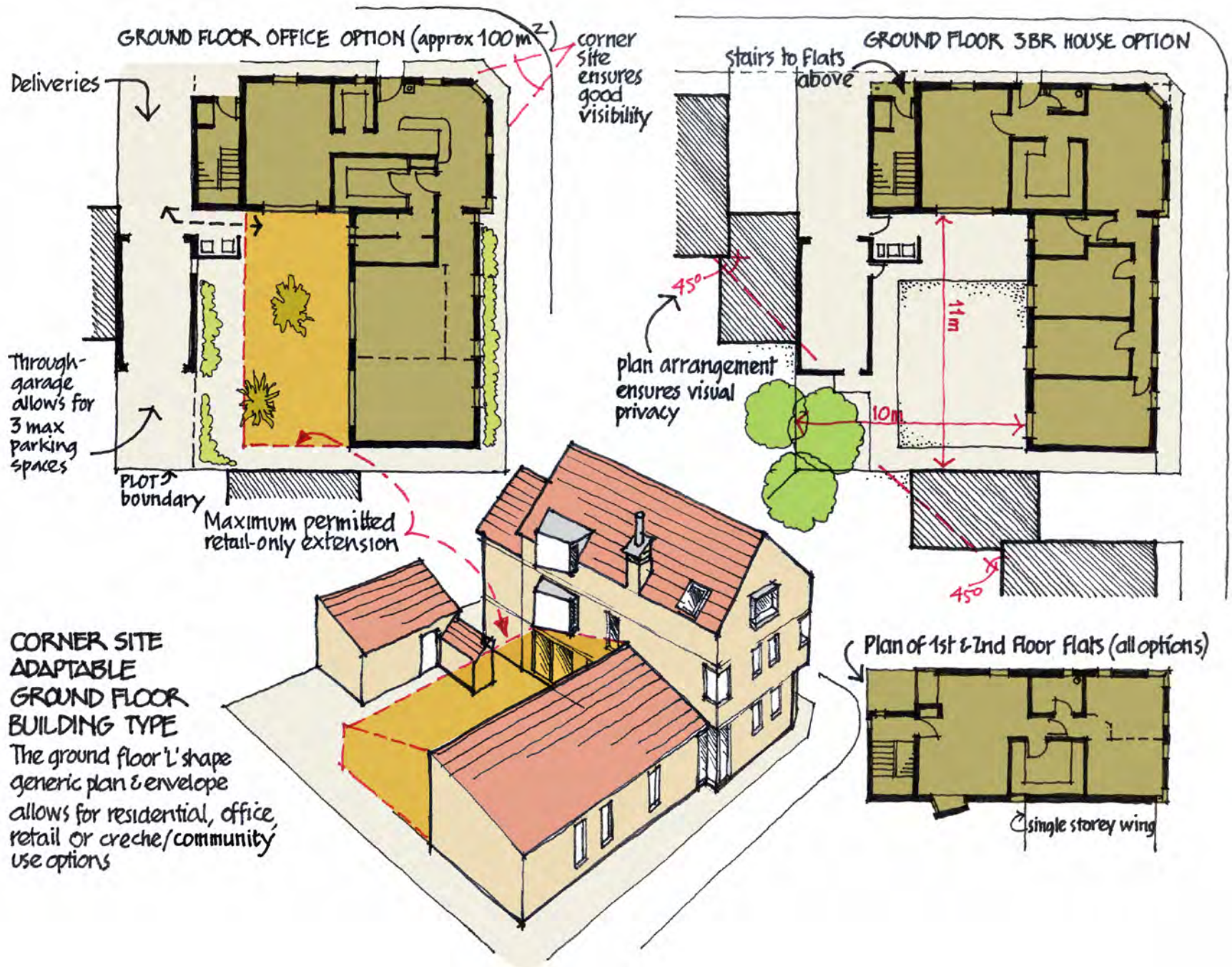



**Building for Life** criteria

**Creating a place**

**5. Character** Does the scheme create a place with a locally inspired or otherwise distinctive character?

**8. Easy to find your way around** Is the scheme designed to make it easy to find your way round?

**Street & Home**

**9 Streets for all** Are streets designed in a way that encourage low vehicle speeds and allow them to function as social spaces?

**11 Public and private spaces** Will public and private spaces be clearly defined and designed to be attractive, well managed and safe?

**Sustainable?**

Using locally sourced materials reinforces the character and identity of an area and reduces the need to transport materials.

## 3.18 Materials

### 3.18.1 Building Materials

*Building materials and colours should be chosen for their high quality, to complement site context and to strengthen the local distinctiveness of the area*

**3.18.2** The use of locally relevant building materials, techniques and detailing can reinforce local distinctiveness and strengthen the special character and identity of a place.

**3.18.3** Materials used in boundaries, elevations and roofs should harmonise with the predominant local character, colour tones and texture where these make a positive contribution to the area. For sites with a weak or indifferent context, materials can be used to help introduce a stronger sense of identity to a place. Contemporary schemes can use traditional materials to create distinctive and innovative designs that also connect with and have relevance to the place.

**3.18.4** The number of materials and colours should normally be limited to a small palette range, both within

a façade and within the wider street. The arbitrary use of a variety of materials and colours in an attempt to achieve 'individuality' should be avoided.

**3.18.5** Selection of materials and colours and their distribution across a development should be based upon an understanding of the context and a reasoned approach to the appearance of the scheme as a whole.

**Successful places:**

- Ensure the choice of materials and colours complements those of the existing setting.
- Use the choice of materials to strengthen character and distinctiveness (typical of the settlement and area of landscape character).
- Avoid the arbitrary use of a wide variety of materials and colours.
- Normally avoid harsh contrasts and garish colours.
- Utilise locally produced traditional materials or recycle and re-use building materials such as stone, bricks and tiles, to help integrate a development into its context (provided these are not taken from walls and structures that are themselves important elements of the areas character).



**Above and left** New homes with brick, stone and roof materials chosen to complement their local context and support the distinctiveness of each place

**Sustainable materials?**

Can the environmental life cycle, cost of materials and components be identified?

This should cover:

- the costs of extracting raw materials.
- the renewable nature of raw materials.
- energy costs in the manufacture of materials.
- the environmental costs of transportation to site.
- the ease of re-use and/or recycling.

Further guidance on sustainable construction is available in the Building Research Establishment (BRE) Green Guide.

**3.18.6 Integrity and robustness**

*Materials should be durable, robust and maintainable and chosen with regard to their visual qualities and contribution to the character of the area*

**3.18.7** The choice of materials needs to take account of their durability as well as aesthetic considerations and character.

**3.18.8** It can be tempting to select materials based on their low cost and ease of maintenance, such as the use of moulded glass reinforced plastic (GRP) features. This can be particularly inviting where houses are to be managed by an external organisation such as a housing association. However, low cost, low maintenance materials and inauthentic 'stick-on' additions lack integrity and undermine the quality of place.

**3.18.9** New buildings should possess integrity and normally avoid the use of inauthentic materials or imitation features.

**3.18.10** Where materials are located on a building is also a factor to be considered e.g. siting painted timber boarding high up on a flatted development makes it inaccessible and difficult to maintain once it begins to deteriorate and likely to lead to its future replacement.



Slate roof with a thin leading edge profile provides a high quality finish



Clay pan tiles and stone slates in a rural context



Natural local stone is robust, has integrity and reinforces local distinctiveness



**Above:** Mass produced materials like moulded glass reinforced plastic (GRP) are inauthentic, appear crude and undermine the quality of the development

**Successful places:**

- Use robust, locally relevant materials that will stand the test of time.
- Use and locate materials so they can be easily maintained when they begin to deteriorate.
- Balance considerations of cost and maintenance with the need to achieve visual harmony, quality and integrity.



Traditional materials of brick, timber and stone combined in a contemporary design



**Building for Life** criteria

**Street & Home**

**12 External storage and amenity space** Is there adequate external storage space for bins and recycling as well as vehicles and cycles?

## 3.19 Servicing

**3.19.1** Practical servicing requirements are a necessary design consideration, but they can impact on the quality of place. Servicing needs are likely to include access for service vehicles, adequate space to store bins and recycling containers, the placement of utility meters and provision of storage for dirty items such as bikes and pushchairs.

### 3.19.2 Bin storage provision

*Each dwelling should have an adequate storage area for refuse and recycling containers, designed and sited so as not to detract from the appearance of the development and to allow bins to be safely and conveniently taken to the collection point*

**3.19.3** Each local authority has its own refuse collection and recycling system. Table 6 summarises each council's requirements for the number and type of bins or recycling containers.

**3.19.4** Each plot must include sufficient space for the storage of the type and number of containers operated by the waste collection authority. Where bin storage areas are provided for individual dwellings, an area measuring 1.4sqm per bin should allow sufficient space for storage, access and handling of the bin.

**Table 6** Bin storage requirements by Waste Collection Authority

	No. of bins	Bin size/ volume (litres)	Communal bin (flats) (litres)	Recommended Carry Distance (BS5906 2005)
<b>Chesterfield Borough Council</b>	3 bin system	240	1100	Two-wheel containers -15m
	Black bin residual waste bin	(option to opt for 140l bins for 1 bed units)	660 (for development of 4 flats or less)	Four-wheeled containers - 10m
	Green bin green waste			MfS – suggests 30m is also reasonable but recognises the BS Standard guidance
	Blue Bin dry recyclables			
<b>Contact:</b> Environmental Services, Waste Management Unit (tel. 01246 345345)				
<b>Bolsover District Council &amp; North East Derbyshire District Council</b>	3 bin system		1100 (equivalent to storage for 5 units)	Two-wheel containers - 15m
	Black bin residual waste	240		Four-wheeled containers - 10m
	Green bin garden waste			
	Burgundy bin dry recyclables			
<b>Contact:</b> 01246 242424 Street Services (Bolsover District Council)				
<b>Contact:</b> 01246 231111 Streetscene Services (North East Derbyshire District Council)				
<b>Bassetlaw District Council</b>	2 bin system	240	1100 bins for residual and recycling; or	Two-wheel containers - 15m
	Blue bin dry recyclables	(option to opt for 140 bins)	Others may have a 240 bin for each flat.	Four-wheeled containers - 10m
	Green bin residual waste		"Pods" that contain a 360 bin for recycling at some flats	
<b>Contact:</b> Environment Services Department (tel. 01909 534501)				

**Good Practice**

Typical wheelie bin sizes (cm)

**140 litre bin**

H. 1060, W. 480 D. 550

**240 litre bin**

H. 1070, W. 585, D. 740

**360 litre bin**

H. 1090, W. 600, D. 880

**660 litre bin**

H. 340, W. 1220, D. 950

**1100 litre bin**

H. 1300, W. 1220, D. 1070

(N/B Dimensions are a general guide only)

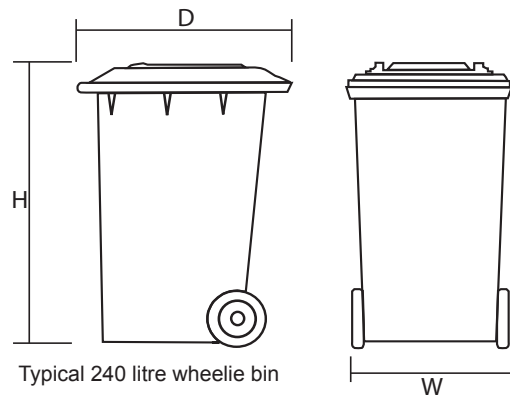
**3.19.5 Siting and design**

Bin storage areas should be conveniently located to enable bins to be easily moved to the collection point, without the need for bins to be taken through a building (excluding garages, carports or similar external covered spaces). Bin storage within garages is acceptable, provided the garage design is big enough to comfortably accommodate both a vehicle and the required waste storage (see 3.8 Parking).

**3.19.6** Waste storage areas located on property frontages are convenient for the purposes of collection but can be visually intrusive and detract from the appearance of the street. Proposals must therefore balance the need for bin stores to be not only convenient and robust, but also visually sympathetic. They should be positioned to avoid or minimise any adverse visual intrusion into the street scene or other publicly visible locations.

[Refuse storage space] *This can be over-designed, and there are many examples of ugly dustbins concealed inside even more ugly bin enclosures - little temples which make an inappropriate celebration out of storing refuse...*

Metric Handbook (3rd Ed. 2008)

**3.19.7 Security**

Careful consideration should also be given to their positioning and design for reasons of safety and security.

**3.19.8** In communal buildings, waste storage chambers provide bin storage for communal waste containers, as either integral or attached annexes or separate buildings. Ideally, they should be accessed externally to prevent access being gained to the building through the waste storage chamber. Where possible, access should also be limited to prevent bin fires.

**3.19.9** Communal bin storage areas or compartments should also be well lit, both for both convenience and safety.



**Above/centre:** Bin storage discreetly integrated behind front entrance gate piers



**Above:** Bins obstruct parking where insufficient space has been provided to store waste and recycling containers



**Above:** Communal bin storage integrated into a lean-to, behind a secure gate and with external access only



**Above:** Lack of adequate storage resulting in bins left on public frontages

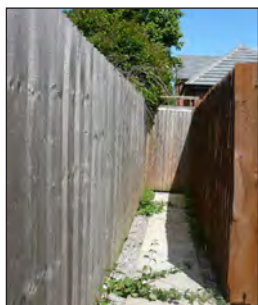
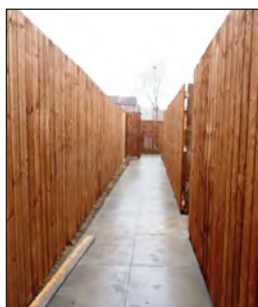

Rear-access paths are unwelcoming, raise potential safety concerns and waste valuable space. Poor maintenance of paths contributes to their lack of appeal

### 3.19.10 Rear-access paths

In the layout of terraced housing rear-access paths enable the movement of refuse bins, garden equipment etc. without the need to pass through the house. However, they are wasteful of valuable space and often long, narrow, poorly lit and unwelcoming spaces. This discourages their use and can cause bins to be left on frontages, detracting from the street scene. For reasons of safety and security, convenience, character and maximising garden sizes, rear-access paths should normally be avoided.

**3.19.11** Where an access path is required this should normally be provided between units below an oversailing storey or 'ginnel'. These reinforce their privacy and security and are an established feature of the area. They can also be grouped with entrances to form interesting elements and attractive arrangements on a facade.

**3.19.12** If rear access paths for multiple dwellings are unavoidable, these should be minimised and their adverse effects mitigated by keeping them short, direct, and serving as few properties as possible. Any boundaries should incorporate open/trellis panels to allow overlooking of the path.

**Right:** New houses with rear garden access via a shared ginnel avoiding the need for rear access lanes

**Far right:** Entrances and a ginnel arranged and detailed to form an interesting grouping

## STORAGE OF RECYCLING MATERIALS, BICYCLES, ETC

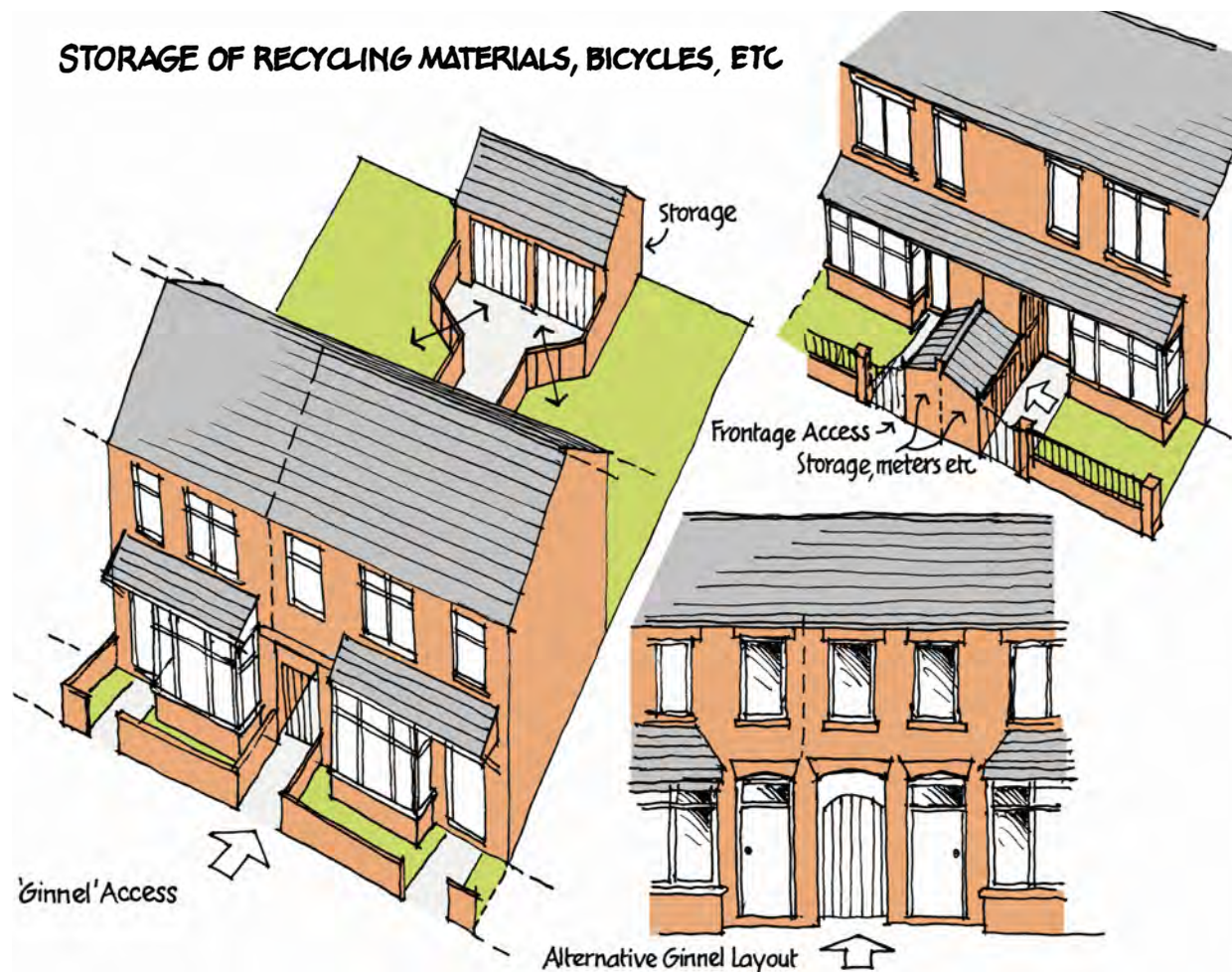

**3.19.13 Bin Carry Distances**

Residents should not normally be required to carry waste more than 30m (excluding vertical distance) to a bin storage point.

**3.19.14** Where bins are unable to be taken to the edge of the street, for collection (such as flats with large communal bins), waste operatives should not normally be expected to move 4-wheeled containers more than 10m or 2-wheeled containers 15m to the waste collection vehicle (as recommended by BS 5906:2005), although Manual for Streets (2007) indicates that up to 30m can be a reasonable carry distance. If proposals intend to site bin stores that require bins to be carried further than 10m or 15m respectively, the advice of the waste collection authority should be sought to determine if this is acceptable.

**3.19.15** Designs should also ensure that waste containers can be left out for collection without unduly blocking the footway or causing an unnecessary obstruction to pedestrians. In some circumstances a specific bin collection area may be necessary to ensure this is managed appropriately.

**3.19.16** Developers and their designers are encouraged to liaise with the local planning authority and the waste collection authority to reach a mutually acceptable agreement on waste storage capacity, siting, access and design considerations.



Bin storage areas shown on a layout drawing to demonstrate that these servicing requirements have been addressed (Drawing courtesy of Walker Troup Architects)



**Above:** Communal bin stores positioned discretely between buildings with a short level access to the street for ease of access on collection day

**Successful places:**

- Provide sufficient space to store the type and number of bins and recycling containers provided by the waste collection authority.
- Locate and design storage areas so they are convenient but not visually intrusive.
- Avoid locating bin storage where it will obstruct parking or access.
- Ensure suitable access between bin collection points and service vehicle access.
- Design bin storage areas to be discrete, functional and robust.
- Use ginnel passages between terraced houses (in preference to rear lanes) to provide direct and secure access to gardens and bins.
- Any gates securing an access path should be visible from or close to the street facing that elevation of the property.
- Avoid rear paths as a means of providing rear access to terraced houses but, if unavoidable, minimise the number and extent and mitigate their shortcomings.

**Useful References**

BS 5906:2005 Waste Management in Buildings Code of Practice, BSI

Manual for Streets, 2007, DCLG, DoT, WAG

The Building Regulations - Approved Document H: Drainage and waste disposal (2006 - updated 2010), ODPM

(see Section H6 Solid Waste Storage, ODPM)

**3.19.17 Access for service vehicles**

*Layouts should facilitate access by service vehicles and be designed so that any turning areas do not dictate the form of layout, but are incorporated within it*

**3.19.18** Waste storage and collection regimes affect quality of place by influencing the size and type of vehicles that will require access.

**3.19.19** Waste collection requirements should be an integral part of street design and layouts should make provision for public service vehicles (i.e. refuse collection) and general deliveries to gain effective access. However, this should not be at the expense of the quality of place.

**3.19.20** The inclusion of turning areas should normally be avoided by designing layouts as through routes. This obviates the need for heavy vehicles to reverse, as reversing is a serious hazard to pedestrians and other road users. If a turning area is required this must not dictate the form of layout (as with a standard turning head) but be incorporated within a space that forms part of the public realm, within which a service vehicle can turn.

**3.19.21** Sufficient space for a three-point turn within the turning space is normally desirable; although where turning is likely to be infrequent or where pedestrian and traffic flows are low more complex turning manoeuvres may be acceptable.

**3.19.22** Cars parked inconsiderately in turning areas can obstruct service vehicles and cause difficulty with bin collections. The provision of adequate residential parking is therefore an important factor in the design and layout to ensure adequate service access.

**3.19.23** Vehicle tracking/swept path analysis should be used to assess the accessibility of layouts and spaces to show that they are capable of accommodating a service vehicle (see Table 7 for refuse vehicle dimensions).

**Successful places:**

- Provide access and turning for service vehicles without being designed with only these needs in mind e.g. within spaces designed as part of the public realm.
- Demonstrate the ability of a space to accommodate a turning service vehicle using swept path analysis.
- Provide reasonable access between waste storage areas and collection vehicles.
- Are robust, fit for purpose and capable of withstanding the demands of heavy vehicles.

**Good Practice**

- Waste collection vehicles should be able to get within 25m of the waste storage point.
- Gradients should not exceed 1:12.
- There should be no more than three steps to negotiate for waste containers up to 250 litres (ideally there should be none) and no steps where larger waste containers are in use.

Source: Schedule 1, Part H, Building Regulations (2000) (N/B BS 5906: 2005 recommends shorter distances).

- The maximum reversing distance for service vehicles is 12m.

Source: BS 5906: 2005

	Vehicle Type/ Model	Length (m)	Width (m)	Gross Weight (fully laden)
<b>Chesterfield Borough Council</b>	Dennis OLYMPUS - 8x4 MS Chassis	11.430	2.530	32000kg
<b>Bolsover District Council</b>	Mercedes Econic 6x2 Mid-steer	10.581	2.530	32000kg
<b>NEDDC</b>	Mercedes Econic 6x2 Mid-steer	10.581	2.530	32000kg
<b>Bassetlaw District Council</b>	Mercedes Econic 8x4	11.5	2.530	32000kg

**Table 7** Service Vehicle Dimensions by waste collection authority (largest vehicle used is shown)





Cars parked within a turning head cause an obstruction to service vehicles needing to turn



Streets and turning areas must be tested to ensure they are capable of accommodating large service vehicles

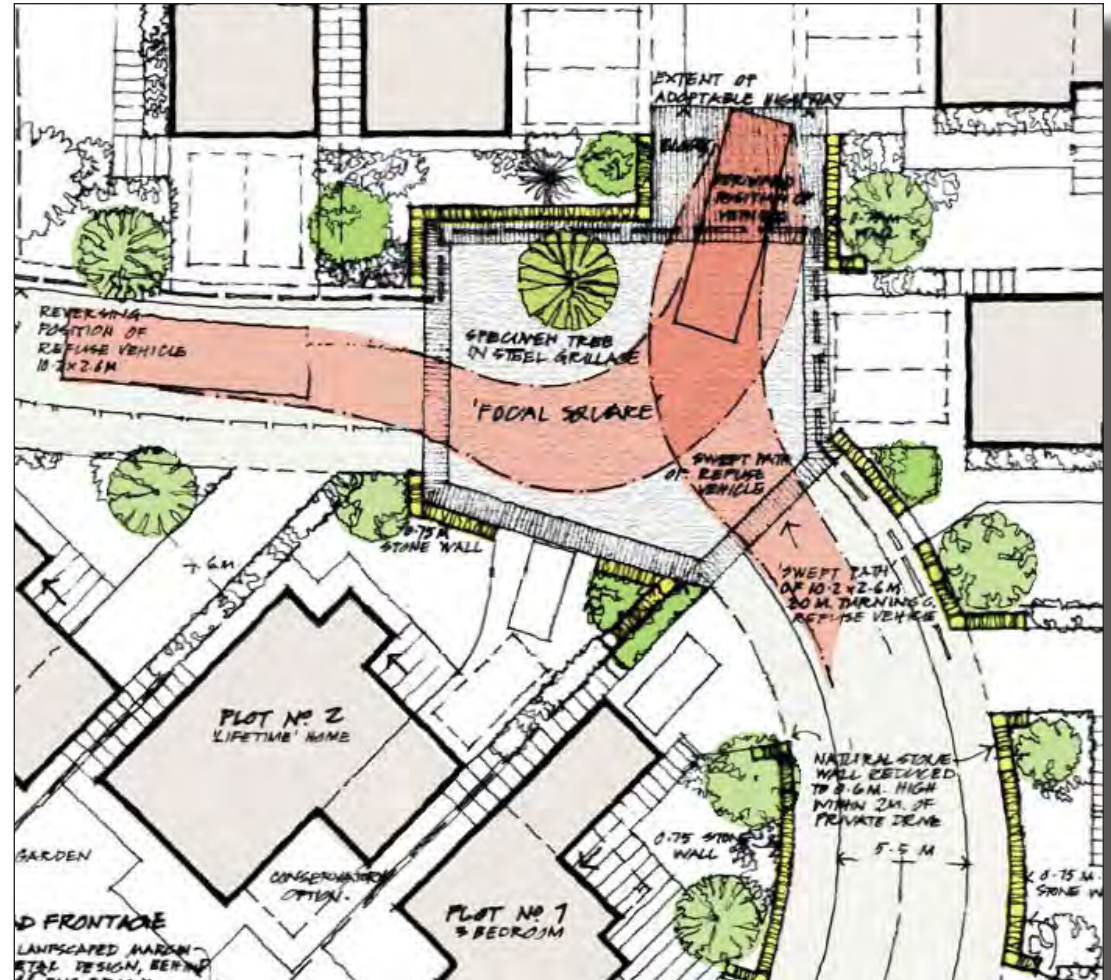

Vehicle tracking used to demonstrate that a refuse collection vehicle is able to turn within a focal space rather than a standard turning head arrangement. (Drawing courtesy of Pinfold Securities and David Black, Architect)

### 3.19.24 Storage of dirty items

*Dwellings should be provided with an area suitable for storing dirty items, appropriate to the size and type of accommodation*



Secure ground floor bicycle and pram storage to flats



With careful design utility areas provide some scope for storing items such as pushchairs

**3.19.25** The inclusion of adequate storage space is essential for the convenience and running of any home. This should include space for storage of outside items such as bicycles, pushchairs, shopping trolleys, garden tools and so on.

**3.19.26** The location and amount of this type of storage will vary depending on the nature and size of the dwelling. Often this is most appropriately located in outbuildings, although the dimensions of garages should be able to accommodate both a car and storage.

**3.19.27** Where there is no convenient access to secure external storage, outside items may potentially be stored internally. This should be in addition to normal domestic storage space. For example a utility room could also serve as an area of dirty storage, if it is of sufficient size to act as both a store and still remain functional.

**3.19.28** For flats, bicycle and pushchair storage in communal stores should be weather protected, easily accessible, safe and personalised wherever possible. It should not be located in habitable rooms or on balconies.

#### Successful places:

- Provide adequate dirty storage to meet the likely needs of the household.
- Ensure external dirty storage is weather protected, accessible, safe and secure.
- Provide some additional space for internal dirty storage areas where it cannot be accommodated outside.

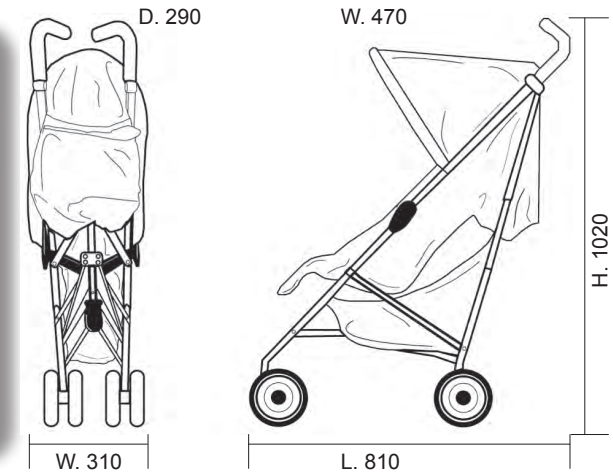

Typical dimensions of a lightweight buggy (folded and extended)

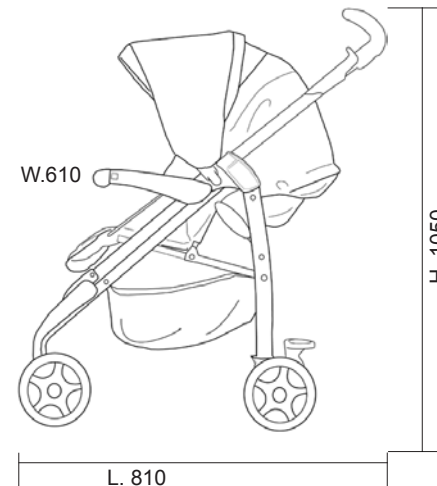

Typical dimensions of a pram (extended)

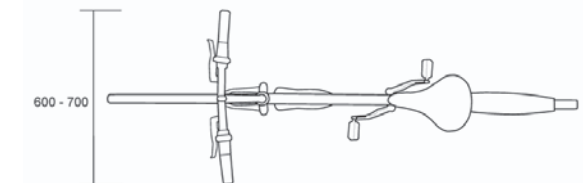
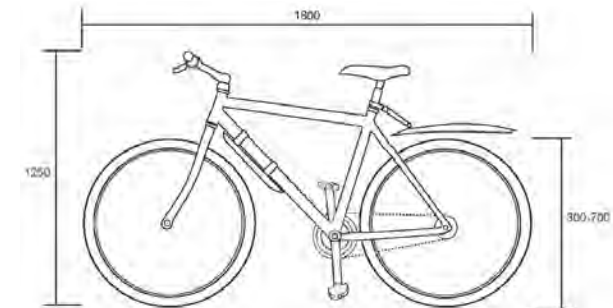

Typical dimensions of an adult bicycle

### 3.19.29 Utility meters

**3.19.30** Utility meters are a necessary but often unsightly feature of modern residential developments. Meter boxes should normally be positioned discretely on an outside wall so they are accessible without the need to enter the dwelling.

**3.19.31** For reasons of safety and security the siting of utility meters should be on the public side of any side/rear fences or gates. Where meters can only be positioned on visible elevations they must be sited to minimise their prominence and factory finished in a colour that complements rather than stands out from the background materials.

**3.19.32** In the case of multi-occupancy developments, where possible utility meters should be located on the ground floor between access controlled doors (air lock system) so that access can be restricted to the meters.

**3.19.33** Utility meters must be positioned discretely and coloured so they do not appear dominant or detract from the appearance of the building or development.



Meter boxes prominently positioned on front elevations detract from the appearance of these houses



Meter boxes carefully located on a flank wall and coloured to complement the brick tone



A meter box positioned on a rear boundary wall to an internal parking court and colour coded to the brickwork



Where meter boxes can only be positioned on a prominent elevation this should be finished in a colour to complement the background material

#### Successful places:

- Position meter boxes with consideration to minimising their visual prominence and impact.
- Finish meter boxes in a colour that blends in with chosen background material and colour.
- Locate utility meters having regard to safety and security considerations.



A meter box sited discretely within a porch enclosure



Hangar Hill, Whitwell - Northern Taverns Ltd

---

# Management and Maintenance

## Enduring quality

---

*“Good places that are actively managed and safe will encourage a positive neighbourliness and a sense of belonging”.*

Urban Design Compendium 2: Delivering quality places, English Partnerships & The Housing Corporation

- 4.1 Adoption and Management
  - 4.2 Street trees and Planting
  - 4.3 Managing Physical Assets
-



## 4.1 Adoption and Management

### 4.1.1 Ensuring long term quality

The on-going management and maintenance of places is a key aspect of their long-term viability and quality. Our streets, parks and public spaces must provide high quality places that can be easily maintained at a reasonable cost. Maintenance issues and costs therefore need to be considered as part of the design process to ensure that maintainable schemes can be achieved and managed thereafter.

**4.1.2** Funds spent on a good design and hard wearing materials can be saved through lower maintenance costs over the lifetime of the asset.

### 4.1.3 Adoption of highways

Developers should work closely with the planning and highway authorities during the design stages to ensure that their adoption requirements can be achieved without undermining the quality of the public realm. This is particularly important where schemes propose creative or non-standard design solutions in order to resolve any issues around adopting highways at an early stage.

**4.1.4** Derbyshire County Council (DCC) and Nottinghamshire County Council (NCC) are the highway authorities for the areas covered by this SPD. Both authorities have adopted the 6C's Highways Design Guide (three cities and three counties) which is

hosted by Leicestershire County Council. This guide details issues relating to the design and adoption of new roads.

**4.1.5** In order to be adopted, all aspects of the public realm need to satisfy the technical requirements of the relevant adopting authority.

### 4.1.6 Safety and quality audits

The need for a safety audit should be discussed with the highway authority at an early stage. A safety audit is not normally required for streets designed and built for residential purposes, but may be prudent where a scheme proposes an innovative or non-standard design. This could be subject to a group professional review which includes a quality and safety audit. They are normally undertaken at each stage of the design process (feasibility, detailed design and on completion).

**4.1.7** A quality audit addresses all aspects of street design including qualitative considerations. This normally includes their effectiveness for allowing movement of all traffic, including pedestrians, cyclists and people with impaired mobility as well as road safety, quality of place and visual appeal.

**4.1.8** The format can be used to identify and resolve any issues that arise as part of the safety audit process. It provides the basis of a documented record for consideration of

the issues, to demonstrate that these have been fully considered and appropriately addressed.

### 4.1.9 Swept path analysis

It may be necessary to demonstrate that the proposed junctions and turning areas are capable of accommodating the movements of service vehicles, buses and emergency vehicles. Applicants may be required to provide evidence in the form of swept path analysis to show that access and essential manoeuvres can be achieved in an acceptable way. This should be established at an early stage.

**4.1.10** Road construction and materials must be capable of withstanding the loads and amount of traffic they will be expected to carry.

#### Useful Reference

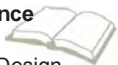

6C's Highway Design Guide

[www.leics.gov.uk/htd](http://www.leics.gov.uk/htd)



**Good Practice**



Where it is proposed to use alternative materials or incorporate non-standard features the highway authority will need to be satisfied that these are:

- Easy to maintain and replace.
- Durable.
- Safe for purpose.
- Sustainable.
- Appropriate to the local character.

Source: 6C's Highway Design Guide

**4.1.11 Commuted payments**

If streets and public spaces are to be adopted the layout and selection of materials must be acceptable to the adopting highway authority.

**4.1.12** If proposals include features that do not relate to essential highway functions of the street (such as alternative materials, street trees/planting, extraneous areas of road space not necessary to the operation of road, as in a public square) the highway authority will need to be satisfied that such features do not place an additional unnecessary burden on maintenance budgets.

**4.1.13** Where alternative materials or non-standard features are agreed in principle with the highway authority, it will normally be necessary to make a commuted payment to cover the additional costs that will be incurred in their future maintenance.

**4.1.14** The 6C's Highway Design Guide details the requirements of the commuted sums policy. This covers a range of materials and features, including alternative materials and finishes such as block paving and surface dressings, bollards and street tree planting.

**4.1.15** The appropriate mechanism for the payment of commuted sums related to highway requirements is normally via the section 38 and/or section 278 agreement process under the Highways Act 1980 (as amended).

Areas outside the essential functioning of the highway, likely to require a commuted payment

Area of adoptable highway

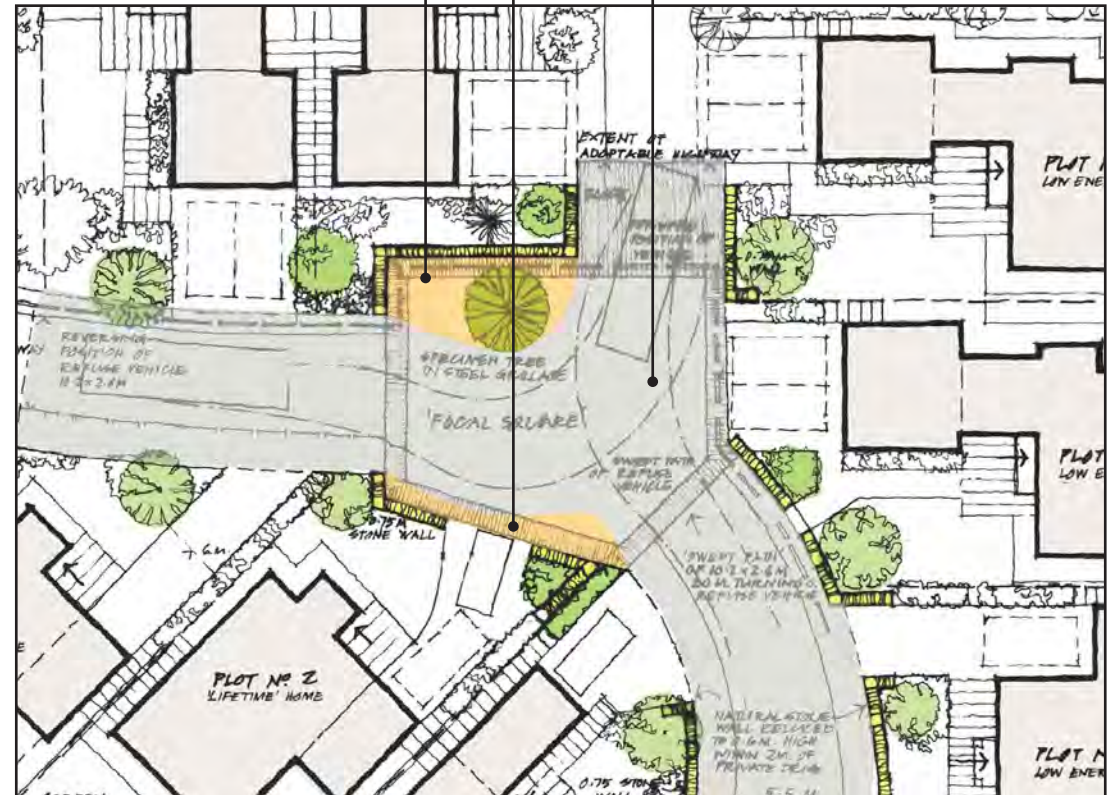

An example of a space where those areas outside that which is essential to the functioning of the highway (indicated in orange) would be likely to require a commuted payment for the highway authority to adopt these areas as part of the highway and to cover its future maintenance. (Drawing courtesy of Pinfold Securities and David Black, Architect)

**Useful Reference**



Commuted Sums for Maintaining Infrastructure Assets: Guidance Document

County Surveyors Society (2010)

www.cssnet.org.uk



## 4.2 Street trees and planting

### Good Practice



Other factors to be considered that influence the selection of trees when deciding upon species, position and spacing:

- Likely future mature size of tree or group of trees.
- Existing tree species, numbers and varieties.
- Local native species.
- Soil type, e.g. acid or alkali, freely or poorly drained site conditions; e.g. sheltered or exposed, root problems, especially on shrinkable clay soils and surface rooting trees, if proposed near to pathways.
- Proximity of roads, public rights of way, paved surfaces, buildings, lighting and services.
- Nuisance; for example, fruiting, common lime aphids etc.



A poorly located tree in relation to the adjoining street lamp will block its light

**4.2.1** Trees and soft landscape can make an important contribution to the appearance and character of a street, along with other environmental benefits.

**4.2.2** The highway authority will require payment of a commuted sum towards future maintenance for each tree, shrub or area of planting that is proposed within the highway in order for it to be adopted (see 6C's Highway Design Guide for details).

**4.2.3** Separate approval is required from the highway authority for any landscape proposed within the highway. N/B this is in addition to any approval granted by the local planning authority for landscape that forms part of a planning permission or requirement by condition.

**4.2.4** The selection of tree species and their siting within the street scene requires careful consideration and balancing of: respect of:

- Maintaining adequate visibility from junctions and accesses.
- The positioning of trees in relation to street lighting to avoid undue reduction in light levels.
- Avoiding conflict with existing or proposed utilities and drains.
- Maintaining reasonable levels of natural surveillance to frontages, parking areas and streets.

**4.2.5** You are recommended to engage the services of a chartered landscape architect to advise and prepare suitable proposals for the landscape of the development. Further details on soft landscape and trees are set out in the 6C's Highway Design Guide and must comply with the required specifications.

**4.2.6** This guidance sets out design considerations for tree planting, which includes:

- Excavation of tree planting pits and specification of the growing medium.
- Tree planting and staking.
- Grilles and guards in paved areas.
- Watering.
- Tree specifications.
- Establishment maintenance for new trees.
- Maintenance of existing trees and vegetation.

**4.2.7** Trees within the highway should provide sufficient planting space to enable the tree to become established, while maintaining a safe and functioning street and footway. Normally a 2m wide footway will need to be maintained, in addition to the area necessary for planting. Tree root barriers are also likely to be required to manage root spread, protect utilities and assist in maintaining even surfaces.



A properly designed and constructed tree pit means that the tree will have a greater chance of becoming established and a long term addition to the street scene



A suitable tree grille provides protection for the tree against soil compaction whilst allowing air and water to reach the roots which are essential for it to thrive





## 4.3 Managing Physical Assets

**4.3.1** Where parks or public spaces are provided these may be adopted by the local authority (borough, district, town or parish) subject to the developer meeting obligations in respect of the transfer of the land in an appropriate condition and provision of commuted payments towards future maintenance. Such provisions are normally set out in a Section 106 legal agreement attached to the planning permission. Other physical assets, such as sustainable urban drainage systems (SUDS) would need to be adopted by the relevant responsible body.

**4.3.2** Applicants should discuss adoption and management requirements with the local authority at an early stage to determine the necessary provisions for adoption and any likely commuted sums associated with its future management and maintenance.

**4.3.3** If a developer does not propose to convey public spaces for adoption, it will be necessary to ensure that suitable alternative arrangements are put in place to secure its on-going management and maintenance.

**4.3.4** In all cases the developer must make it clear how public spaces are to be managed and maintained (whether public or private) and put firm arrangements in place to demonstrate how this will be delivered. Undertakings should also be given that any spaces not adopted by a public body will remain publicly accessible.

**4.3.5** Maintenance options by a non-public body could include:

- Maintenance by a Bonded Management Company.
- Maintenance by a Charitable Trust.
- Other solutions through special arrangement, such as maintenance by residents and/or businesses, where it can be demonstrated to be a responsible, properly constituted body with the necessary capabilities and resources to fulfill its role.

**4.3.6** Knowing how a place will be managed will influence how it is designed. The chosen management structure should have the appropriate skills and resources to manage the assets for which it is responsible, both now and into the future.

### Useful Reference

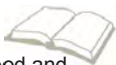





























From 2012/13 the Flood and Water Management Act (2010) places a duty on County or unitary authorities to adopt SUDS.

Schedule 3, Section 32, Sustainable Drainage – Duty to adopt



**Notation**

-  Application site boundary
-  Proposed built form
-  Key building
-  Indicative built form context (phase two)
-  Affordable housing (20%)
-  Recycling / cycle / garden store
-  Public open space (refer to landscape drawings for details)
-  Incidental amenity area
-  Woodland Park
-  Existing vegetation
-  Indicative planting (refer to landscape drawings for details)
-  Foot/cycleway links
-  Shared surface streets
-  Visitor parking
  
- B1  1.0m metal railings (ball finial)
- B2  1.0m metal railings (spike finial)
- B3  1.8m close board fence
- B4  1.8m brick wall
- B5  1.0m low brick wall
- B6  1.5m brick wall with metal railings
- B7  0.75m low brick wall with planting
- B8  1.8m rendered wall with rough stone detail
- B9  1.0m palisade fence
- B10  1.2m 'Estate' railings
- B11  1.8m c/b fence with 300mm trellis top
  
-  Metal bollards
-  Timber bollards
-  Metal gates (Feature gate 1 & 3)
-  Timber gates (Feature gate 2 & 4)
-  Feature gate 5 in wall
-  Rear/side garden gate

noise attenuation

---

# Appendix

---

**Appendix**    Local Policies by Local Planning Authority  
                  National Policy Documents  
                  National Good Practice Guidance

---

Local Authority and current relevant plan	Core Strategy Policies	Local Authority and current relevant plan	Saved Local Plan policies
<p>Bassetlaw District Council</p> <p>Core Strategy and Development Management Policies DPD</p>	<p><b>Core design policy:</b> DM4: Design &amp; Character</p> <p><b>Associated policies that link with design issues:</b> DM3: Development in the Countryside</p> <p>DM5: Housing Mix &amp; Density</p> <p>DM8: The Historic Environment</p> <p>DM9: Green Infrastructure, Biodiversity &amp; Geodiversity Landscape, Open Space &amp; Sports Facilities</p> <p>DM13: Sustainable Transport</p>	<p>Bolsover District Council</p> <p>Bolsover District Local Plan (2000)</p>	<p>Core design policy GEN2: Impact of Development on the Environment</p> <p><b>Associated policies that link with design issues:</b> GEN1: Minimum Requirements for Development</p> <p>GEN5: Land Drainage</p> <p>GEN11: Development Adjoining the Settlement Framework Boundary</p> <p>HOU5: Outdoor Recreation and Play Space Provision for New Housing Developments</p> <p>HOU6: Affordable Housing</p> <p>TRA7: Design for Accessibility by Bus</p> <p>TRA10: Traffic Management</p> <p>TRA13: Provision for Cyclists</p> <p>TRA15: Design of Roads and Paths to Serve New Development</p> <p>ENV5: Nature Conservation Interests throughout the District</p> <p>ENV8: Development Affecting Trees and Hedgerows</p> <p>CON1: Development in Conservation Areas</p> <p>CON4: Development Adjoining Conservation Areas</p> <p>CON10: Development Affecting the Setting of Listed Buildings</p>

NB: On adoption of Local Plans any existing saved local plan policies will be superseded by new policies and supplementary planning guidance will be reviewed or updated in due course.

Local Authority and current relevant plan	Local Plan: Core Strategy Policies	Local Authority and current relevant plan	Saved Local Plan Policies
<p>Chesterfield Borough Council</p> <p>Chesterfield Local Plan: Core Strategy (2013)</p>	<p><b>Core design policy</b> CS18: Design</p> <p><b>Associated policies that link with design issues:</b> CS5: Renewable Energy CS6: Sustainable Design and Construction CS19: Historic Environment CS7: Managing the Water Cycle CS9: Green Infrastructure and Biodiversity CS20: Influencing the Demand for Travel</p>	<p>North East Derbyshire District Council</p> <p>North East Derbyshire Local Plan (2001 – 2011)</p>	<p>Core design policy H12: Design &amp; Layout of New Housing</p> <p><b>Associated policies that link with design issues:</b> GS1: Sustainable Development GS5: Settlement Development Limits GS10: Crime Prevention GS12: Access for All NE1: Landscape Character NE2: Special Landscape Areas NE3: Protecting and Managing Features of Importance to Wild Flora and Fauna NE7: Protection of Trees &amp; Hedgerows BE1: General Design Principles BE5: Percent for Art BE9: Development in the Vicinity of a Listed Building BE11: Development Within and Adjoining Conservation Areas H5: Domestic Extensions T2: Highway Access and the Impact of New Development Interim Sustainable Buildings Policy</p>

## National Planning Policy Framework (NPPF)

NPPF (March 2012) sets the national planning framework for all forms of development with a clear presumption in favour of sustainable development.

A key aspect of the NPPF is the promotion of good design quality and recognising that well designed places are central to sustainable development. It states that good planning and good design are indivisible and makes it clear that poorly designed proposals should be refused permission.



## National Guidance

By Design (2000) and the Urban Design Compendium 1 & 2 (2007) promote the importance of urban design in new development and provide best practice guidance. The central message from both documents is that careful assessments of places, well-drafted planning policies, well-designed proposals, robust decision-making and a collaborative approach are needed if better places are to be created.



Better Places to Live by Design (2001) is the companion guide to PPG3. It aims to promote deeper thought and greater flair from those entrusted with creating better places to live. Following on from *By Design* it draws together the principles of good urban design as they relate to the residential environment to help move the practice of good design forward. It uses case studies to look at the qualities associated with successful residential places in order to provide guidance on implementing better quality residential developments.



Building for Life 12 (BfL12) is the national standard for well-designed homes and neighbourhoods and is a partnership between CABE at the Design Council, the Home Builders Federation (HBF) and Design for Homes. It comprises 12 questions in three chapters and uses a traffic light system to determine whether schemes are well designed and identify areas that may require improvement. It is recommended that schemes achieve as many greens as possible, minimise ambers and avoid reds.



Safer Places (2004) establishes design principles that can help reduce criminal activity or anti-social behaviour. The focus is on 'designing out crime' via natural surveillance, access or management/ownership. It highlights how crime and anti-social behaviour can be reduced if careful thought is given to how new development relates to the public realm.



Manual for Streets (2007) and its companion guide, Manual for Streets 2 (2010) represents a new way of thinking about highway design, with a focus on streets as places in their own right rather than simply roads for moving traffic. Streets should be designed with the needs of all users in mind.



Code for Sustainable Homes (CfSH) is a single national standard to guide industry in the design and construction of sustainable housing. Local planning authorities are increasingly referring to the Code through their planning policies and compliance with the Energy category is mandatory under the Building Regulations. The Code comprises six levels to communicate the overall environmental performance of a new home against nine sustainability categories.



# THE 21<sup>ST</sup> CENTURY HOUSE



## Successful Places

A Guide to Sustainable Housing Layout and Design

## Supplementary Planning Document

First Edition 2013 (Version 1.0)

